

7.0 KVA DIESEL LIGHTING TOWER - 1 PHASE

FEATURES & BENEFITS

- Maximum 7.7 kVA, 230V, 1500 RPM
- Constant voltage AVR (Automatic Voltage Regulator)
- 12 Volt Electric Starter
- 150 Litre Fuel Tank, 60 Hours @ 75% load
- Lighting Tower Version
- 3 Cylinder, In-Line, water cooled, four stroke
- Single Phase Output
- DeepSea DSE4520 Digital Control Panel
- 4 x Stabilisers (Manual)
- Roadworthy trailer with spare wheel
- 4 x 150W LED Lights (Upgradeable to 4 x 400W)

 Perkins

 DEEP SEA
DSE ELECTRONICS



GENERAL DATA	
Model:	DM-Y-LTM
Prime Power (P.R.P):	7.0 kVA
Stand-by Power (L.T.P):	7.7 kVA
Amps:	29 A
Power Factor / COS:	0.8
Frequency:	50 Hz
Voltage:	230 V
Phases:	Single Phase
Engine Speed:	1500 RPM
Length:	2850 mm
Width:	1400 mm
Height (Mast down / up):	2100 / 4500 mm
Weight:	800 kg's
Tank Capacity:	150 l

ADDITIONAL	
Running Time:	60 Hours @ 75% load
Structure Type:	Lighting Tower
Socket & Plug:	1 x 220v (32A)
Output Sockets:	2 x 16A 220V RSA Plugs
Battery Charging:	Input socket 220v
Fire Extinguisher:	Optional Extra
Fuel Cons. @ 100% Load:	3.3
Fuel Cons. @ 75% Load:	2.5
Fuel Cons. @ 50% Load:	1.7

Optional Extras

- Remote monitoring via DSEWebNet (DSE890)
- 9KG fire Extinguisher & Bracket,
- Earth Spike & Clamp with 1m Earth Cable,
- Wheel Chock (x4 per tower light)

ENGINE DATA	
Brand:	Perkins
Model:	403A-11G
Type:	3 Cylinder, In-Line, water cooled, four stroke
Starting System:	12 Volt Electric Starter
Auto-Decompression:	Yes
Cubic Capacity (l):	1.116
Compression Ratio:	23.5:1
Rated Power (kW/RPM):	9
Fuel Type:	Diesel
Lube Oil:	15W40
Low Pressure Alert:	Yes
Low Fuel Cut Out:	Yes

CONTROL PANEL	
Model:	DeepSea DSE4520
Type:	Digital Control Panel
Auto Mains Failure:	Yes
Scheduled Start/Stop:	Up to 8
Remote Monitoring:	Optional

ALTERNATOR	
Model:	NSM
Pole Number:	4
Excitation Mode:	Self Excitation

Remote monitoring requires a valid 4G enabled SIM card or a LAN connection with Internet access. Coverage is dependent on a strong Internet connection.

Johannesburg
011 397 7373

Pietermaritzburg
033 007 0812

Nelspruit
013 007 1753

Bloemfontein
051 001 1429

ALTERNATORI MONOFASE - 4 Poli

SINGLE-PHASE ALTERNATORS - 4 Poles

K132
Brushless a condensatore
Brushless with Capacitor

KR132
A spazzole con AVR-d
Brush with AVR-d



Caratteristiche tecniche

K132
Tensione standard 50Hz: 115/230V, 120/240V 60Hz: 110/220V, 120/240V Altri valori a richiesta
Classe d'isolamento H
Protezione IP 20
T.H.D. ≤ 5%
Precisione tensione +5%, -8% (cosφ = 1)
Capacità di spunto (Icc ≥ 3In)
KR132
Tensione standard 50Hz: range 220÷240V 60Hz: range 220÷240V Altri valori a richiesta
Classe d'isolamento H
Protezione IP 20
T.H.D. ≤ 6%
Precisione tensione ± 1,5% (indipendentemente dal cosφ)
Capacità di spunto (Icc ≥ 3In)
Regolatore automatico di tensione AVR 760D
<ul style="list-style-type: none"> • Provvisto di protezioni per Sottovolatilità, Massima tensione, Massima corrente di eccitazione, Sovraccarico prolungato (max kVA) • Possibilità di regolare la tensione a distanza

Technical characteristics

K132
Standard voltage 50Hz: 115/230V, 120/240V 60Hz: 110/220V, 120/240V Other voltages on request
Insulation class H
Protection IP 20
T.H.D. ≤ 5%
Voltage accuracy +5%, -8% (cosφ = 1)
Starting capacity (Icc ≥ 3In)
KR132
Standard voltage 50Hz: range 220÷240V 60Hz: range 220÷240V Other voltages on request
Insulation class H
Protection IP 20
T.H.D. ≤ 6%
Voltage accuracy ± 1,5% (regardless of cosφ)
Starting capacity (Icc ≥ 3In)
Automatic Voltage Regulator AVR 760D
<ul style="list-style-type: none"> • Supplied with protections for Underspeed, Maximum voltage, Maximum excitation current, Prolonged overload (max kVA) • Remotely adjustable voltage regulator

Modello Model	Potenza Output Power		Potenza assorbita Driving Power		Potenza Output Power		Potenza assorbita Driving Power		Peso Weight			
	cosφ 1 [kVA]	cosφ 0,8 [kVA]	4/4 - cosφ 1 [kW] η %		cosφ 1 [kVA]	cosφ 0,8 [kVA]	4/4 - cosφ 1 [kW] η %		cone [kg]	B34 [kg]	SAE [kg]	
50Hz - 1500rpm					60Hz - 1800rpm							
K132 A	3,5	---	4,7	74,0	4,5	---	6,0	75,0	---	---	36	
K132 B	5,0	---	6,5	77,0	6,0	---	7,7	78,0	---	---	41	
K132 C	7,0	---	9,0	78,0	8,0	---	10,1	79,0	---	---	49	
K132 D	8,5	---	10,8	79,0	10,0	---	12,5	80,0	---	---	57	
KR132 A	3,5	2,8	4,7	74,0	4,5	3,2	6,0	75,0	---	---	38	
KR132 B	5,0	4,0	6,5	77,0	6,0	4,8	7,7	78,0	---	---	43	
KR132 C	7,0	5,5	9,0	78,0	8,0	6,5	10,1	79,0	---	---	51,5	
KR132 D	8,5	6,8	10,8	79,0	10,0	8,0	12,5	80,0	---	---	60	

Dimensioni di ingombro

Overall Dimensions

SAE

K132

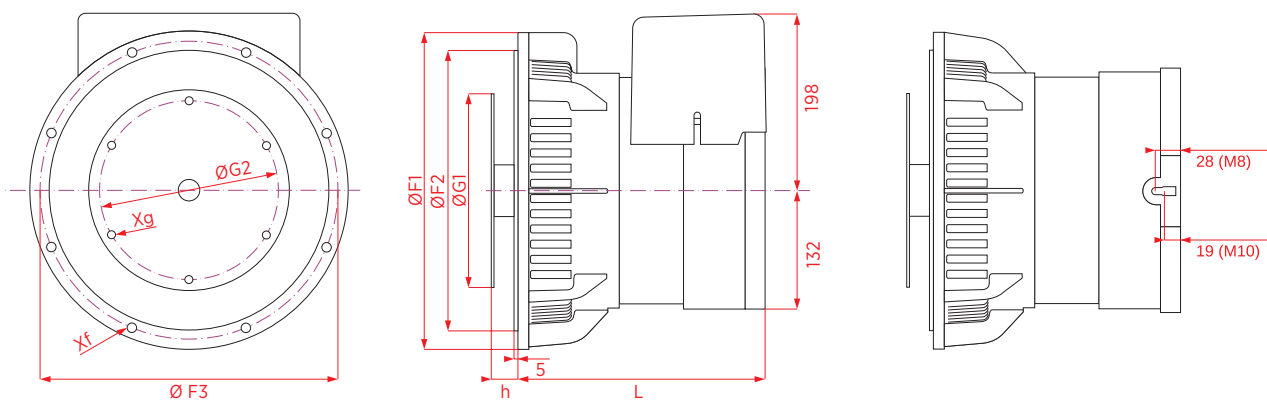

KR132

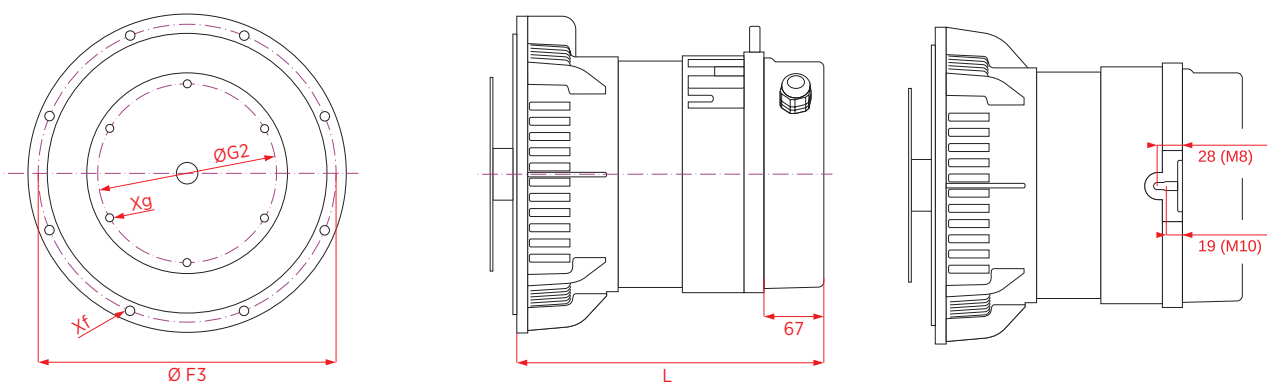

SAE	Flangia Flange			
	ØF1	ØF2	ØF3	Xf
	[mm]			
5	356	314,33	333,40	Ø11 (8)
4	404	361,95	381,00	Ø11 (12)

SAE	Giunto Joint			
	ØG1	ØG2	E	Xg
	[mm]			
6,5	215,90	200,02	30,2	Ø9 (6)
7,5	241,30	222,25	30,2	Ø9 (8)

Model	K132	KR132
	L	
	[mm]	
A	248	315
B	268	335
C	293	360
D	318	385

Dati tecnici non impegnativi: NSM si riserva il diritto di apportare modifiche senza l'obbligo di darne preventiva comunicazione. Technical data not binding: NSM reserves the right to modify the contents without prior notice.

DSE4520 MKII

AUTO MAINS FAILURE CONTROL MODULE



KEY FEATURES

- Load unbalanced alarm
- Configurable for use as an auto start and AMF control module
- J1939-75 support and CAN alarm ignore function
- Alternator frequency & CAN speed sensing in one variant
- Largest back-lit icon display in its class
- Heated display option
- Real time clock provides accurate event logging
- Fully configurable via the fascia or PC using USB communication
- Extremely efficient power save mode
- 3 phase generator sensing
- 3 phase mains (utility) sensing
- Compatible with 600 V ph to ph nominal systems
- Generator/load power monitoring (kW, kV A, kV Ar, pf)
- Accumulated power monitoring (kW h, kVA h, kVAR h)
- Generator overload protection (kW)
- Generator/load current monitoring and protection
- Fuel and start outputs (configurable when using CAN)
- 4 configurable DC outputs
- 3 configurable analogue/digital inputs
- 4 configurable digital inputs
- Configurable staged loading outputs
- 3 engine maintenance alarms
- Engine speed protection
- Engine hours counter
- Engine pre-heat
- Engine run-time scheduler
- Engine idle control for starting & stopping
- Tier 4 engine instrumentation screens
- Battery voltage monitoring
- Start on low battery voltage
- Configurable remote start input
- 1 alternative configuration
- Comprehensive warning, electrical trip or shutdown protection upon fault condition
- LCD alarm indication
- Event log (50)
- Fuel solenoid pulling circuit
- On-screen line diagram on/off functionality
- Configurable CAN instrumentation (10)
- Water in fuel digital input
- Tank bund alarm digital input
- Generator at rest output
- ECU periodic wake-up for information retrieval
- Back-light power-save mode
- Adjustable delay crank timer
- Pre/post heat functionality
- Overload protection
- Mains/generator A/C system selection
- Output timer for external audible alarm

KEY BENEFITS

- Automatically transfers between mains (utility) and generator
- Hours counter provides accurate information for monitoring and maintenance periods
- User-friendly set-up and button layout for ease of use
- Multiple parameters are monitored simultaneously which are clearly displayed on the large back-lit icon display.
- The module can be configured to suit a wide range of applications
- Uses DSE Configuration Suite PC Software for simplified configuration
- Compatible with a wide range of CAN engines including Tier 4
- Licence-free PC software
- IP65 rating (with optional gasket) offers increased resistance to water ingress

SPECIFICATIONS

DC SUPPLY

CONTINUOUS VOLTAGE RATING
8 V to 35 V Continuous

CRANKING DROPOUTS

Able to survive 0 V for 50 mS, providing supply was at least 10 V before dropout and supply recovers to 5 V. This is achieved without the need for internal batteries. LEDs and backlight will not be maintained during cranking.

MAXIMUM OPERATING CURRENT

85 mA at 12 V, 96 mA at 24 V

MAXIMUM STANDBY CURRENT

51 mA at 12 V, 47 mA at 24 V

MAXIMUM SLEEP CURRENT

35 mA at 12 V, 32 mA at 24 V

MAXIMUM DEEP SLEEP CURRENT

<10 uA at 12 V, <10 uA at 24 V

MAINS (UTILITY)

VOLTAGE RANGE
15 V to 415 V AC (Ph to N)
26 V to 719 V AC (Ph to Ph)

FREQUENCY RANGE

3.5 Hz to 75 Hz

OUTPUTS

OUTPUT A (FUEL)

10 A short term, 5 A continuous, at supply voltage

OUTPUT B (START)

10 A short term, 5 A continuous, at supply voltage

AUXILIARY OUTPUTS C, D, E & F

2 A DC at supply voltage

GENERATOR

VOLTAGE RANGE
15 V to 415 V AC (Ph to N)
26 V to 719 V AC (Ph to Ph)

FREQUENCY RANGE

3.5 Hz to 75 Hz

DIMENSIONS

OVERALL
140 mm x 113 mm x 43 mm
5.5" x 4.4" x 1.7"

PANEL CUT-OUT

118 mm x 92 mm
4.6" x 3.6"

MAXIMUM PANEL THICKNESS

8 mm
0.3"

STORAGE TEMPERATURE RANGE

-40 °C to +85 °C
-40 °F to +185 °F

OPERATING TEMPERATURE RANGE

-30 °C to +70 °C
-22 °F to +158 °F

OPTIONAL PARTS

PART	PART NUMBER
IP65 Gasket	020-282

RELATED MATERIALS

TITLE

DSE4510/20 MKII Installation Instructions
DSE4510/20 MKII Operator Manual
DSE4510/20 MKII Configuration Suite PC Manual

PART NO.

053-190
057-260
057-258

DEEP SEA ELECTRONICS LTD UK

Highfield House, Hunmanby Industrial Estate, Hunmanby YO14 0PH
TELEPHONE +44 (0) 1723 890099
EMAIL sales@deepseaelectronics.com **WEBSITE** www.deepseaelectronics.com

DEEP SEA ELECTRONICS INC USA

3230 Williams Avenue, Rockford, IL 61101-2668 USA
TELEPHONE +1 (815) 316 8706 **FACSIMILE** +1 (815) 316 8708
EMAIL usasales@deepseaelectronics.com **WEBSITE** www.deepseaelectronics.com

DSE4520 MKII

AUTO MAINS FAILURE CONTROL MODULE

The DSE4520 MKII Auto Mains (Utility) Failure Control Module is suitable for a wide variety of single gen-set applications.

Whilst maintaining functions included within higher end controllers, such as generator and load power monitoring, the DSE4520 MKII provides the user with an outstanding size to feature ratio.

Monitoring engine speed, oil pressure, coolant temperature, frequency, voltage, current, power and fuel level, the modules will give comprehensive engine and alternator protection. This will be indicated on the largest back-lit LCD icon display in its class via an array of warning, electrical trip and shutdown alarms.

The module provides electronic J1939 (CAN) and non-electronic (alternator frequency sensing) engine support for diesel, gas and petrol engines all in one variant. With a number of flexible inputs, outputs and protections, the module can be easily adapted to suit a wide range of applications.

Through USB communication the module can be easily configured using the DSE Configuration Suite PC Software or can be fully configured through the module's front panel editor.

All DSE products are supported by our dedicated technical support team, which gives customers and end users access to 24 hour help and advice.

*AVAILABLE VARIANTS

4520-05 Auto Mains Failure (Rtc)

ENVIRONMENTAL TESTING STANDARDS

ELECTRO-MAGNETIC COMPATIBILITY

BS EN 61000-6-2
EMC Generic Immunity Standard for the Industrial Environment
BS EN 61000-6-4
EMC Generic Emission Standard for the Industrial Environment

ELECTRICAL SAFETY

BS EN 60950
Safety of Information Technology Equipment, including Electrical Business Equipment

TEMPERATURE

BS EN 60068-2-1
Ab/Ae Cold Test -30 °C
BS EN 60068-2-2
Bb/Be Dry Heat +70 °C

VIBRATION

BS EN 60068-2-6
Ten sweeps in each of three major axes
5 Hz to 8 Hz at +/-7.5 mm,
8 Hz to 500 Hz at 2 gn

HUMIDITY

BS EN 60068-2-30
Db Damp Heat Cyclic 20/55 °C at 95% RH 48 Hours
BS EN 60068-2-78
Cab Damp Heat Static 40 °C at 93% RH 48 Hours

SHOCK

BS EN 60068-2-27
Three shocks in each of three major axes
15 gn in 11 mS

DEGREES OF PROTECTION PROVIDED BY ENCLOSURES

BS EN 60529
IP65 - Front of module when installed into the control panel with the optional sealing gasket.

COMPREHENSIVE FEATURE LIST TO SUIT A WIDE VARIETY OF GEN-SET APPLICATIONS

