

45 KVA DIESEL GENERATOR

FEATURES & BENEFITS

- Maximum 50 kVA, 380V, 1500 RPM
- Constant voltage AVR (Automatic Voltage Regulator)
- 12 Volt Electric Starter
- 100 Litre Fuel Tank, 12 Hours @ 75% load
- Silent Version (± 72 dBa)
- Three cylinder, Turbocharged, Water cooled Diesel Engine
- Three Phase Output
- DeepSea DSE6120 Digital Control Panel
- Low oil pressure system
- Low water cut out engine protection



GENERAL DATA	
Model:	BPD45S3-P
Prime Power (P.R.P):	45 kVA
Stand-by Power (L.T.P):	50 kVA
Amps:	75.9 A
Power Factor / COS:	0.8
Frequency:	50 Hz
Voltage:	380 V
Phases:	Three Phase
Engine Speed:	1500 RPM
Length:	2200 mm
Width:	900 mm
Height:	1150 mm
Weight:	930 kg's
Tank Capacity:	100 l

ADDITIONAL	
Running Time:	12 Hours @ 75% load
Structure Type:	Silent
Noise Level (7m):	72 dBA
Auto Voltage Regulator:	Constant voltage AVR
ISO9001 Certified:	Yes
CE Certified:	Yes
Fuel Cons. @ 100% Load:	10.7
Fuel Cons. @ 75% Load:	8.2
Fuel Cons. @ 50% Load:	5.7

ENGINE DATA	
Brand:	Perkins
Model:	1103A-33TG1
Type:	Three cylinder, Turbocharged, Water cooled Diesel Engine
Starting System:	12 Volt Electric Starter
Auto-Decompression:	Yes
Cubic Capacity (l):	3.3
Compression Ratio:	17.25:1
Rated Power (kW/RPM):	46 / 1500
Fuel Type:	Diesel
Lube Oil:	15W40
Low Pressure Alert:	Yes
Low Fuel Cut Out:	Yes

CONTROL PANEL	
Model:	DeepSea DSE6120
Type:	Digital Control Panel
Analogue Inputs:	6
Mains Phase Voltage:	Yes
Mains Line Voltage:	Yes

ALTERNATOR	
Model:	Leroy Somer - TAL-A42-E
Pole Number:	4
Excitation Mode:	Self Excitation

Johannesburg
011 397 7373

Pietermaritzburg
033 007 0812

Nelspruit
013 007 1753

Bloemfontein
051 001 1429

Technical Data

1100 Series

Gen Set

1103A-33TG1

45,6 kWm @ 1500 rev/min

53,9 kWm @ 1800 rev/min

Basic technical data

Number of cylinders	3
Cylinder arrangement	Vertical in-line
Cycle	Four stroke
Induction system	Turbocharged
Compression ratio	17.25 : 1
Bore	105 mm (4.13 in)
Stroke	127 mm (4.99 in)
Cubic capacity	3.3 litres
Direction of rotation	Clockwise view from front
Firing order	1,2,3
Total weight (engine only)	
-dry	420 kg
-wet	438 kg

Overall dimensions

-height	951 mm (37.44 in)
-length	1049 mm (41.29 in)
-width (including mounting brackets)	634 mm (24.96 in)

Moment of inertia (mk²)

Engine:	
- longitudinal	25 kgm ²
- horizontal	42 kgm ²
- axial	25 kgm ²
Flywheel (polar)	1.14 kgm ²

Centre of gravity (wet)

- forward from rear of block	215 mm (8.46 in)
- above centre line of block	120 mm (4.72 in)
- offset of RHS of centre line	25 mm (0.98 in)

Performance

Steady state speed stability at constant load:

G2 $\pm 0.75\%$

Note: All data based on operation to ISO 3046/1, BS 5514 and DIN 6271 standard reference conditions.

Test conditions

Air temperature	25 °C
Barometric pressure	100 kPa
Relative humidity	30%

Sound level

Overall sound pressure level (cooling pack and air cleaner fitted):	
- at 1500 rev/min	88,2 dBA
- at 1800 rev/min	92,1 dBA

Sound pressure level from the mean of 4 microphones at the front, left, right and above the engine. Exhaust was piped away out of the test cell.

If the engine is to operate in ambient conditions other than those of the test conditions, suitable adjustments must be made for these changes. For full details, contact Perkins Technical Service Department.

General installation

Designation	Units	Type of Operation and Application			
		Prime	Stand-by	Prime	Stand-by
		50 Hz	50 Hz	60 Hz	60 Hz
Gross engine power	kWm	42,2	46,5	50,5	55,6
Brake mean effective pressure	kPa (lbf/in ²)	1023 (148.3)	1128 (163.6)	1020 (147.9)	1124 (163.0)
Mean piston speed	m/s (ft/s)	6,35 (20.8)	6,35 (20.8)	7,62 (25.0)	7,62 (25.0)
ElectropaK net engine power	kWm	41,3	45,6	48,8	53,9
Engine coolant flow 35 kPa restriction	l/min (UK gal/min)	125,5 (27.6)	125,5 (27.6)	151,0 (33.2)	151,0 (33.2)
Combustion air flow	m ³ /min (ft ³ /min)	2,9 (102.4)	3,1 (109.4)	3,7 (130.6)	3,9 (137.7)
Exhaust gas flow (max)	m ³ /min (ft ³ /min)	7,0 (247.2)	7,7 (271.9)	8,8 (310.7)	9,5 (335.4)
Exhaust gas temperature (max) in manifold	°C (°F)	492 (917.6)	537 (999.6)	510 (950.0)	551 (1023.8)
Cooling fan air flow	m ³ /min (ft ³ /min)	53,0 (1871.6)	53,0 (1871.6)	70,0 (2472.0)	70,0 (2472.0)
Overall thermal efficiency	%	39,8	38,7	39,3	39,1
Typical genset electrical unit (0.8 pf 25° C)	kWe	36,0	39,7	42,5	46,9
	kVA	45,0	49,6	53,1	58,7
Assumed alternator efficiency	%	87%			
Energy balance					
Power in fuel (Fuel heat of combustion)	kW (Btu/min)	106,0 (6033.4)	120,0 (6830.3)	129,0 (7342.6)	142,0 (8082.5)
Power output (gross)	kW (Btu/min)	42,2 (2402.0)	46,5 (2646.7)	50,5 (2874.4)	55,6 (3164.7)
Power to cooling fan	kW (Btu/min)	0,9 (51.2)	0,9 (51.2)	1,7 (96.7)	1,7 (96.7)
Power output (net)	kW (Btu/min)	41,3 (2350.7)	45,6 (2595.5)	49,0 (2789.0)	53,9 (3067.9)
Power to coolant and lubricating oil	kW (Btu/min)	26,0 (1479.9)	30,0 (1707.5)	31,0 (1764.5)	34,0 (1935.2)
Power to exhaust	kW (Btu/min)	30,0 (1707.5)	35,0 (1992.1)	39,0 (2219.8)	43,0 (2447.5)
Power to radiation	kW (Btu/min)	7,0 (398.4)	8,0 (455.3)	8,0 (455.3)	9,0 (512.2)

Caution: The airflows shown in this table will provide acceptable cooling for an open power unit operating in ambient temperatures of up to 53 °C (127 °F) or 46 °C (114.8 °F) if a canopy is fitted. If the power unit is to be enclosed totally, a cooling test should be done to check that the engine cooling is acceptable. If there is insufficient cooling, contact Perkins Technical Service Department.

Cooling system

Radiator

- face area 0.276 m² (2.97 ft²)
- rows and materials..... single row aluminium
- matrix density and material Aluminium 12.5 fins/inch
- width of matrix 526 mm (20.7 in)
- height of matrix 524 mm (20.6 in)
- pressure cap setting 107 kPa

Fan

- diameter 457 mm (18 in)
- drive ratio 0.85 : 1
- number of blades 7
- material Composite
- type Pusher

Coolant

- Total system capacity
- with radiator 10.2 l (21.5 pt)
- without radiator 4.4 l (9.2 pt)
- Maximum top tank temperature 110 °C (230 °F)
- Thermostat operating range..... 82 - 93 °C (180 - 199 °F)
- Recommended coolant: 50 % ethylene glycol with a corrosion inhibitor (BS 658 : 1992 or MOD AL39) and 50% clean fresh water.

Electrical system

- Type Negative ground
- Alternator voltage 12 V
- Alternator output 65 amps
- Starter motor voltage 12 V
- Starter motor power 3 kW
- Number of teeth on flywheel 126
- Pull in current of starter motor solenoid 60 amps
- Hold in current of starter motor solenoid 15 amps
- Engine stop solenoid 12 V
- Stop solenoid (minimum)
- pull in current 10 amps
- hold in current 10 amps

Cold start recommendations

- Minimum cranking speed 105 rev/min

Starter specification

Starter motor type	Minimum starting temperature	Lubricating oil viscosity SAE / battery type - values in CCA			
		15W/40	10W/40	5W/40	5W/30
12 volt 3.0 kW	°C (°F)				
	-10 (14)	1 x 660			
	-15 (5) *		1 x 660		
	-20 (-4) *			1 x 660	
	-25 (-13) *				2 x 570

* - Glow plug start aid fitted.

Note: CCA - Cold Cracking Amps to SAEJ537.

Notes:

- Battery capacity is defined by the 20 hour rate
- If a change to a low viscosity oil is made, the cranking torque necessary at lower ambient temperatures is much reduced. The starting equipment has been selected to take advantage of this. It is important to change the appropriate multigrade oil in anticipation of operating in low ambient temperatures.
- Breakaway current is dependent on battery capacity available. Cables should be capable of handling the transient current which may be up to double the steady cranking current.

Exhaust system

- Maximum back pressure
- 1500 rev/min 10 kPa
- 1800 rev/min 15 kPa
- Exhaust outlet size 56 mm (2.2 in)

Fuel System

- Type of injection Direct
- Fuel injection pump Rotary
- Fuel atomiser..... Multi-hole
- Nozzel opening pressure 29,0 MPa (290 bar)

Fuel lift pump

- Type Electrical
- flow/hour 120 - 150 l/h (211 - 264 pt/m)
- pressure 30 - 75 kPa (4.4 - 10.9 psi)
- Maximum suction head:
- 1500 rev/min 20 kPa

Governor type

- Electronic governor Woodward LCS2
- Mechanical and electronic governor speed control to ..ISO 8528, G2

Fuel specification

Fuel Specification	European RF75-T-96 / DIN EN590 / BS2869 class A2
Density (kg/l @ 15 °C)	0,835 - 0,845
Viscosity (mm ² /s @ 40 °C)	2,5 - 3,5
Sulphur content (%)	0,1 - 0,2
Cetane number	45 - 50

Fuel consumption litres/hour (UK gals/hr)

Speed	Power rating				
	110%	100%	75%	50%	25%
1500	12,0 (2.6)	10,7 (2.3)	8,2 (1.8)	5,7 (1.2)	3,4 (0.7)
1800	14,3 (3.1)	12,9 (2.8)	9,9 (2.1)	7,1 (1.5)	4,3 (0.9)

Induction system

Maximum air intake restriction

- clean filter 5 kPa
- dirty filter..... 8 kPa
- air filter type..... Dry

Lubrication system

Lubricating oil capacity

- Total system 8,3 l (17.5 pt)
- Sump minimum 6,2 l (13.1 pt)
- Sump maximum 7.8 l (16.4 pt)
- Maximum engine operating angles:

- front up, front down, right side or left side 25°

Lubricating oil pressure

- relief valve opens 415 - 470 kPa
- at maximum no-load speed 276 - 414 kPa
- Max continuous oil temperature 125 °C (257 °F)
- Oil consumption at full load as a % of fuel consumption 0.15%

1103A-33TG1 ElectropaK - left view

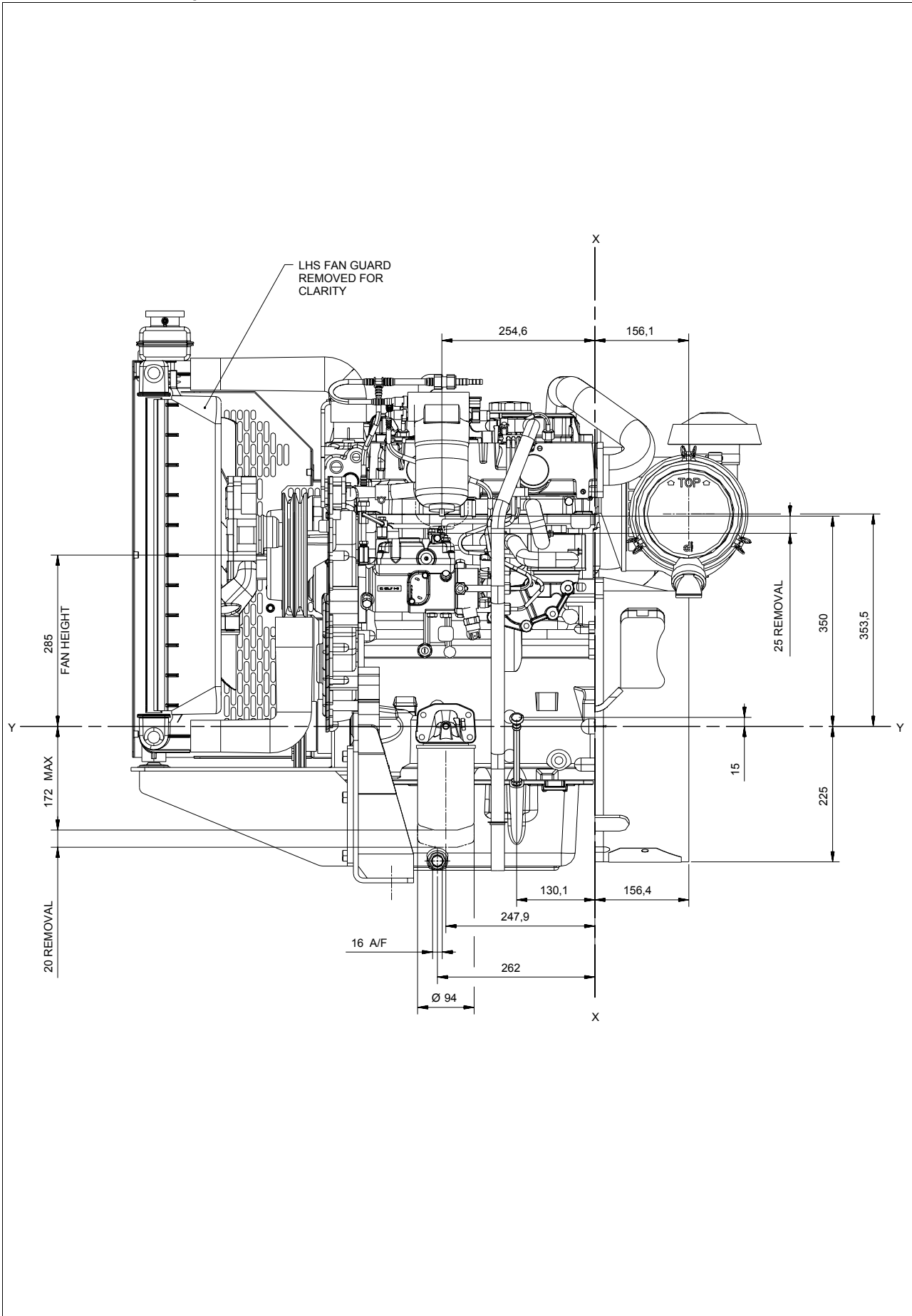

1103A-33TG1 ElectropaK - front view

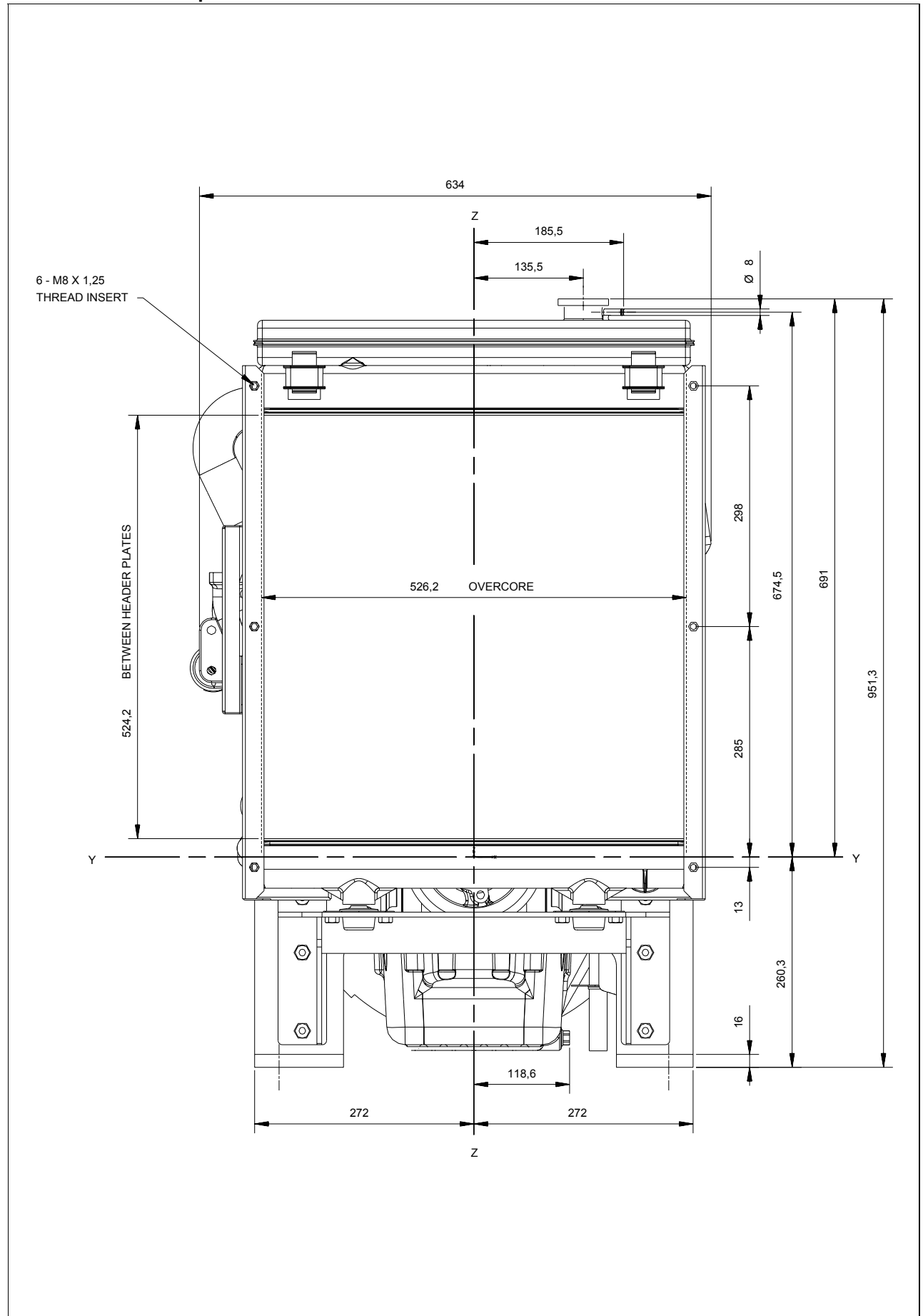

1103A-33TG1 ElectropaK - right view

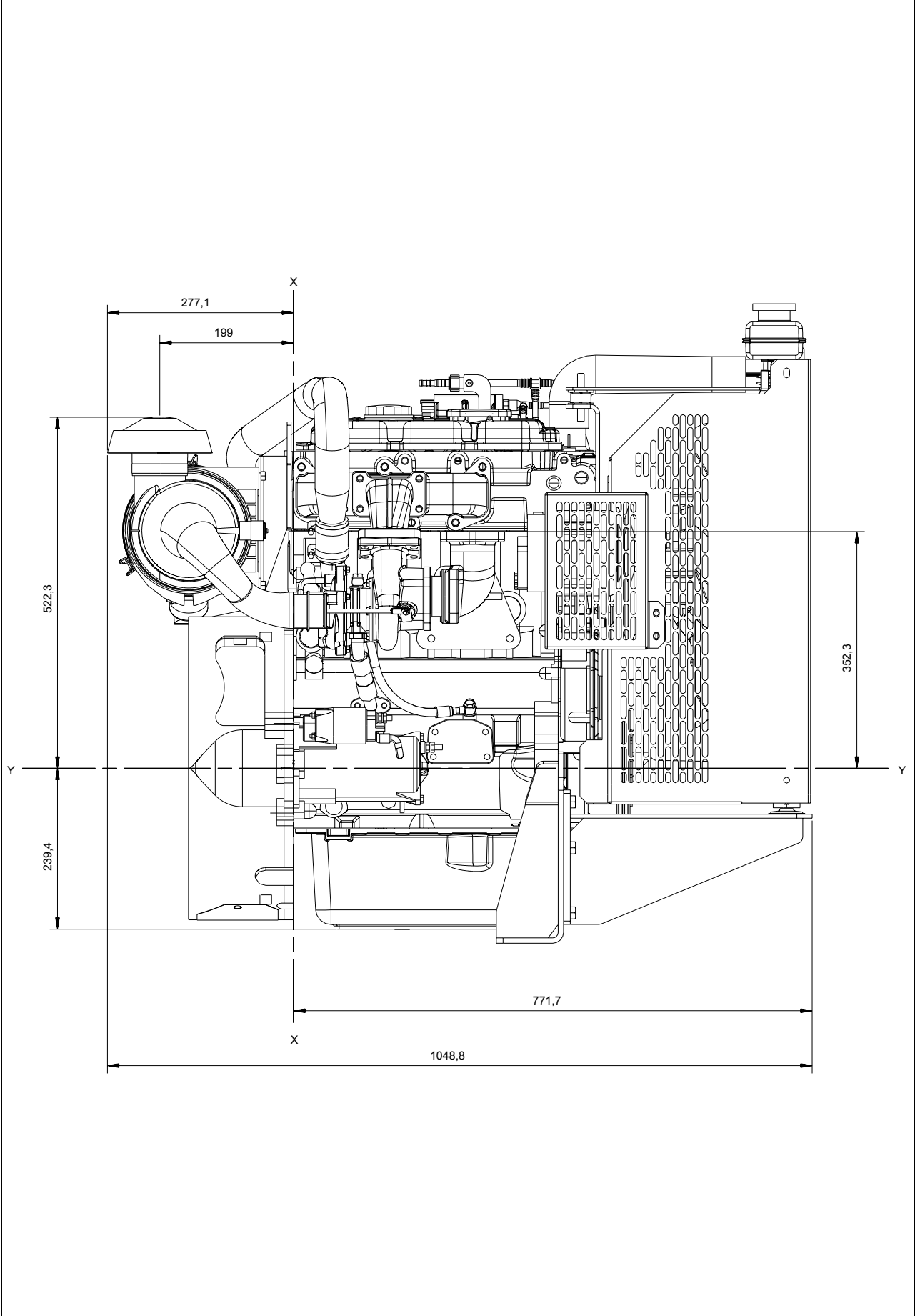

1103A-33TG1 Electropak - rear view

FUEL RETURN CONNECTION TO
SUIT DIA. 8 OR DIA. 10 HOSE.

FUEL INLET CONNECTION
TO SUIT DIA. 8 HOSE

DEUTSCH DT02P
CONNECTOR

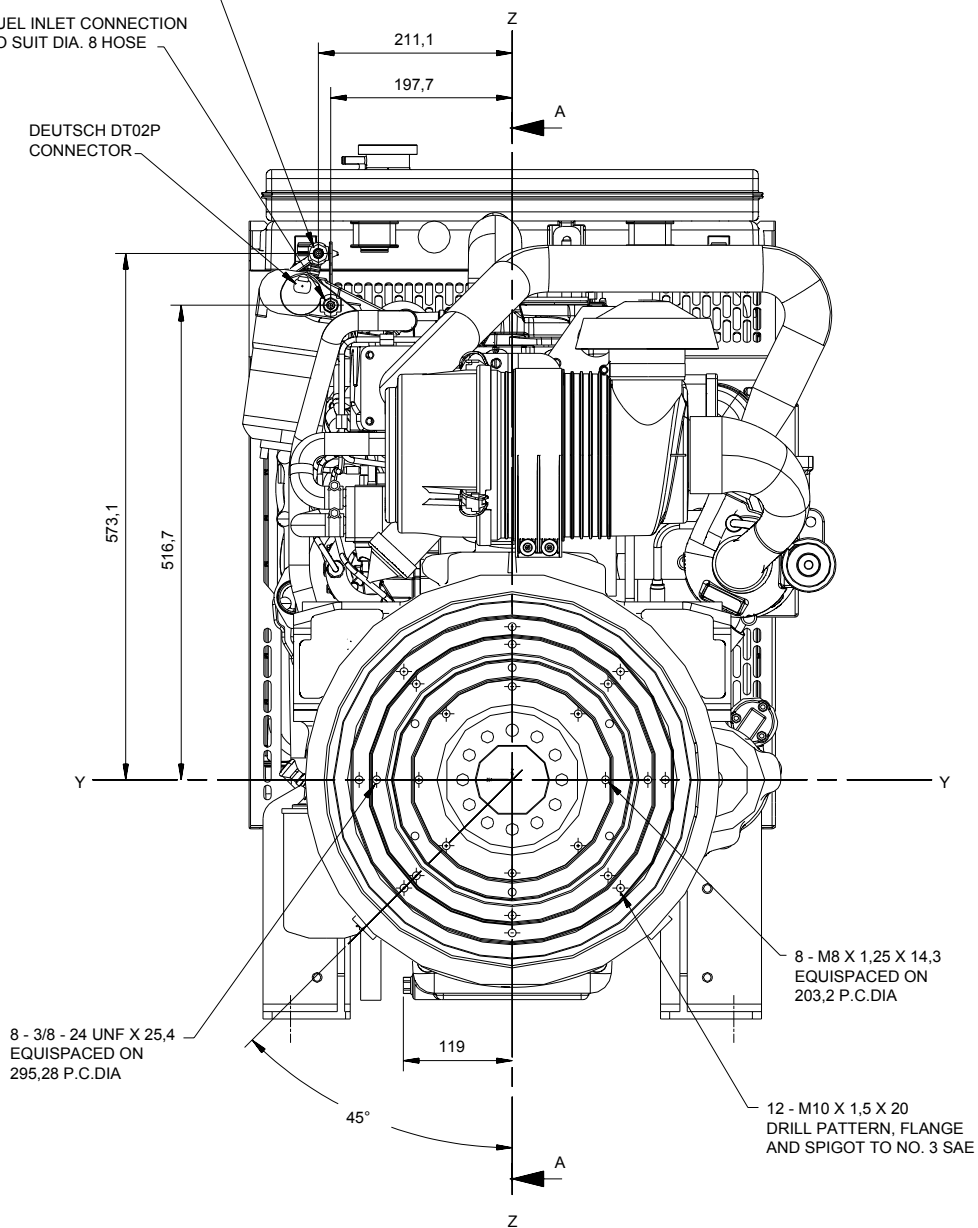

Recommended SAE viscosity

A single or multigrade oil must be used which conforms to API-CG4 / CH4, see illustration below:

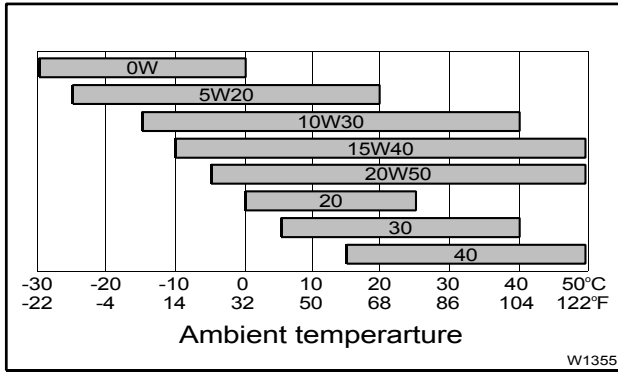

Mountings

Maximum static bending moment at rear face of block ... 791 Nm (583 lb/ft)

Load Acceptance

Initial load application when engine reaches rated speed (15 seconds max after engine starts to crank)			
	Units	1500 rev/min	1800 rev/min
Prime Power	%	90	90
Load	kWm/ kWe	38,0 (32.3)	45,5 (38.2)
Transient frequency deviation	%	< 10	< 10
Frequency recovery	seconds	< 5	< 5

The above complies with requirements of classification 3 & 4 of ISO 8528-12 and G2 operating limits stated in ISO 8528-5. The above figures were obtained under the test conditions as follows:

Engine block temperature ... 105 °C
 Alternator efficiency ... 87%
 Minimum ambient temperature ... 10 °C

Isochronous governing:

- typical alternator inertia ... 0.364 kgm²

All tests were conducted using an engine installed and services to Perkins Engines Company Limited recommendations

The information given in this document is for guidance only.

@ Perkins®

Perkins Engines Company Limited
 Peterborough PE1 5NA United Kingdom
 Telephone +44 (0) 1733 583000
 Fax +44 (0) 1733 582240
 www.perkins.com

All information in the document is substantially correct at the time of printing but may be subsequently altered by the company.

Distributed by

DSE6110/20 MKII

AUTO START & AUTO MAINS FAILURE CONTROL MODULES

DSE6110 MKII

DSE6120 MKII

KEY FEATURES

- Large back-lit text display
- Multiple display languages
- Heated display option available
- DSENet® expansion compatible
- Data logging facility
- Fully configurable via PC using USB communication
- Front panel configuration
- Efficient power save mode
- 3 phase generator sensing
- 3 phase mains (utility) sensing (DSE6120 MKII only)
- Generator/load power monitoring (kW, kV A, kV Ar, pf)
- Accumulated power monitoring (kW h, kVA h, kVAr h)
- Generator/load current monitoring and protection
- Generator overload protection (kW)
- Breaker control via fascia buttons
- Fuel and start outputs, configurable when using CAN
- 4 configurable DC outputs
- 4 configurable analogue/digital inputs
- Support for 0 to 10 V &

- 4 to 20 mA oil pressure sensors
- 6 configurable digital inputs
- Configurable staged loading outputs
- CAN, MPU and alternator speed sensing in one variant
- 3 engine maintenance alarms
- Engine speed protection
- Engine hours counter
- Engine pre-heat
- Engine run-time scheduler
- Engine idle control for starting & stopping
- Fuel pump control
- Real time clock
- Battery voltage monitoring
- Start on low battery voltage
- Configurable remote start input
- 1 alternative configuration
- Comprehensive warning, electrical trip or shutdown protection upon fault condition
- LCD and LED alarm indication
- Customisable information screens
- Configurable event log (100)
- Tier 4 ECO engine support including exhaust fluids & filters

- J1939-75 instrumentation output, configurable CAN instrumentation and alarms
- Start on low battery
- Enhanced alarm functionality
- Low load alarm

KEY BENEFITS

- Automatically transfers between mains (utility) and generator (DSE6120 MKII only)
- Increased input and output expansion capability via DSENet®
- User-friendly set-up and button layout for ease of use
- Multiple parameters are monitored simultaneously which are clearly displayed on a large back-lit text display via multiple languages
- The module can be configured to suit a wide range of applications
- Uses DSE Configuration Suite PC Software for simplified configuration
- Licence-free PC software
- IP65 rating (with optional gasket) offers increased resistance to water ingress

SPECIFICATIONS
DC SUPPLY

CONTINUOUS VOLTAGE RATING
8 V to 35 V Continuous

CRANKING DROPOUTS

Able to survive 0 V for 50 mS, providing supply was at least 10 V before dropout and supply recovers to 5 V. This is achieved without the need for internal batteries. LEDs and backlight will not be maintained during cranking.

MAXIMUM OPERATING CURRENT
100 mA at 12 V, 105 mA at 24 V

MAXIMUM STANDBY CURRENT
60 mA at 12 V, 55 mA at 24 V

MAXIMUM SLEEP CURRENT
40 mA at 12 V, 35 mA at 24 V

GENERATOR & MAINS (UTILITY) VOLTAGE RANGE

15 V to 415 V AC (Ph to N)
26 V to 719 V AC (Ph to Ph)

FREQUENCY RANGE
3.5 Hz to 75 Hz

INPUTS

DIGITAL INPUTS A to F
Negative switching

ANALOGUE INPUT A

Configurable as:
Negative switching digital input
0 V to 10 V
4 mA to 20 mA
0 Ω to 240 Ω

ANALOGUE INPUTS B TO D

Configurable as:
Negative switching digital input
0 Ω to 480 Ω

OUTPUTS
OUTPUT A (FUEL)

10 A short term, 5 A continuous, at supply voltage

OUTPUT B (START)

10 A short term, 5 A continuous, at supply voltage

AUXILIARY OUTPUTS C, D, E & F

2 A DC at supply voltage

DIMENSIONS

OVERALL
216 mm x 158 mm x 43 mm
8.5" x 6.2" x 1.5"

PANEL CUT-OUT

184 mm x 137 mm
7.2" x 5.3"

MAXIMUM PANEL THICKNESS

8 mm
0.3"

STORAGE TEMPERATURE RANGE

-40 °C to +85 °C
-40 °F to +185 °F

OPERATING TEMPERATURE RANGE NON HEATED DISPLAY VARIANT

-30°C to +70°C
-22 °F to +158 °F

HEATED DISPLAY VARIANT

-40 °C to +70 °C
-40 °F to +158 °F

OPTIONAL PARTS

PART	PART NUMBER
IP65 Gasket	020-521

RELATED MATERIALS
TITLE

DSE6110/20 MKII Installation Instructions
DSE6110/20 MKII Operator Manual
DSE6110/20 MKII Configuration Suite PC Manual

PART NO.

053-173
057-226
057-224

DEEP SEA ELECTRONICS PLC UK

Highfield House, Hunmanby Industrial Estate, Hunmanby YO14 0PH
TELEPHONE +44 (0) 1723 890099 **FACSIMILE** +44 (0) 1723 893303
EMAIL sales@deepseapl.com **WEBSITE** www.deepseapl.com

DEEP SEA ELECTRONICS INC USA

3230 Williams Avenue, Rockford, IL 61101-2668 USA
TELEPHONE +1 (815) 316 8706 **FACSIMILE** +1 (815) 316 8708
EMAIL sales@deepseausa.com **WEBSITE** www.deepseausa.com

