

250 KVA DIESEL GENERATOR

FEATURES & BENEFITS

- Maximum 275 kVA, 380V, 1500 RPM
- Constant voltage AVR (Automatic Voltage Regulator)
- 24V Electric Starter
- 300 Litre Fuel Tank, 7 Hours @ 75% load
- Silent Version (± 72 dBa)
- 6 Cylinder, in-line, Water cooled, Turbocharged & Aftercooled
- Three Phase Output
- DeepSea DSE6120 Digital Control Panel
- Low oil pressure system
- Low water cut out engine protection



Perkins LEROY-SOMER DEEP SEA DSE ELECTRONICS

GENERAL DATA	
Model:	BPD250S3-P
Prime Power (P.R.P):	250 kVA
Stand-by Power (L.T.P):	275 kVA
Amps:	412 A
Power Factor / COS:	0.8
Frequency:	50 Hz
Voltage:	380 V
Phases:	Three Phase
Engine Speed:	1500 RPM
Length:	3350 mm
Width:	1100 mm
Height:	1850 mm
Weight:	2615 kg's
Tank Capacity:	300 l

ADDITIONAL	
Running Time:	7 Hours @ 75% load
Structure Type:	Silent
Noise Level (7m):	72 dBA
Auto Voltage Regulator:	Constant voltage AVR
ISO9001 Certified:	Yes
CE Certified:	Yes
Fuel Cons. @ 100% Load:	51.0
Fuel Cons. @ 75% Load:	38.6
Fuel Cons. @ 50% Load:	26.0

ENGINE DATA	
Brand:	Perkins
Model:	1206A-E70TTAG3
Type:	6 Cylinder, in-line, Water cooled, Turbocharged & Aftercooled
Starting System:	24V Electric Starter
Auto-Decompression:	Yes
Cubic Capacity (l):	7.01
Compression Ratio:	15.8:1
Rated Power (kW/RPM):	226 / 1500
Fuel Type:	Diesel
Lube Oil:	15W40
Low Pressure Alert:	Yes
Low Fuel Cut Out:	Yes

CONTROL PANEL	
Model:	DeepSea DSE6120
Type:	Digital Control Panel
Analogue Inputs:	6
Mains Phase Voltage:	Yes
Mains Line Voltage:	Yes

ALTERNATOR	
Model:	Leroy Somer - LSA 46.3 M7
Pole Number:	4
Excitation Mode:	Self Excitation

Johannesburg
011 397 7373

Pietermaritzburg
033 007 0812

Nelspruit
013 007 1753

Bloemfontein
051 001 1429

1200 Series 1206A-E70TTAG3 Diesel Engine – ElectropaK

248.6 kWm (Gross) @ 1500 rpm

240 kWm (Gross) @ 1800 rpm

Perkins is pleased to announce the natural expansion of the 1200 Series to include a new addition to the ElectropaK range.

The whole engine has been built around the demands of our customers and as such offers a great package with a simple integration design.

Perkins have developed a reputation for designing and building reliable and durable engines suitable for the most demanding applications.

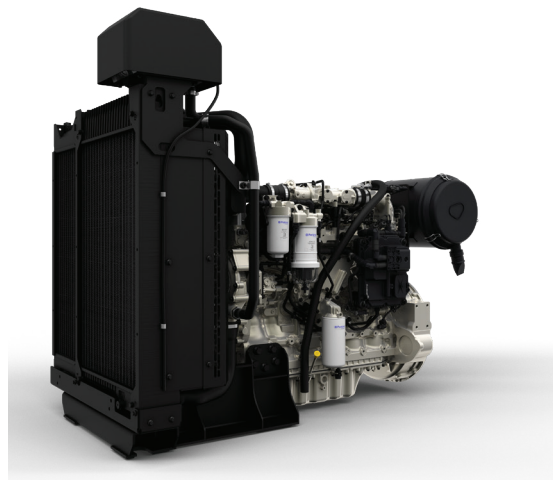

Emissions

Unregulated.

Specification		
Number of cylinders	6 vertical in-line	
Bore and stroke	105 x 135 mm	4.13 x 5.3 in
Displacement	7.01 litres	427.7 in ³
Aspiration	Series turbocharged aftercooled	
Cycle	4 stroke DI	
Combustion system	Direct injection	
Compression ratio	15.8:1	
Rotation	Anti-clockwise, viewed on flywheel	
Total lubricating capacity	13-16 litres	3.4-4.2 US gal
Cooling system	Liquid	
Total coolant capacity	25 litres	6.6 US gal

www.perkins.com

Photographs are for illustrative purposes only and may not reflect final specification.
All information in this document is substantially correct at time of printing and may be altered subsequently.
Final weight and dimensions will depend on completed specification.

Publication No. PN3184/06/18 Produced in England ©2018 Perkins Engines Company Limited

 **Perkins**[®]

THE HEART OF EVERY GREAT MACHINE

1200 Series 1206A-E70TTAG3 Diesel Engine – ElectropaK

248.6 kWm (Gross) @ 1500 rpm

240 kWm (Gross) @ 1800 rpm

Features and benefits

Dependable power

- World-class manufacturing capability and processes coupled with proven core engine designs assure reliability, quiet operation, and many hours of productive life
- Series turbocharging with smart wastegate available on all ratings
- A high power density product that combine dependable power and high efficiency at the same time. Driving lower cost of ownership along with better performance

To find more, visit: www.perkins.com/powerdensity

Flexibility

- Tropical radiator is supplied as standard

Lifetime of low cost

- Fuel consumption optimized prime power and continuous running applications. No additional fluids or additives are required which lowers operating costs
- Hydraulic tappets, multi-vee belts and 500-hour oil change intervals enable low-cost maintenance
- Perkins Platinum Protection – there is also an option to buy a Perkins Platinum Protection policy to cover you beyond the standard warranty period.

Discover more: https://www.perkins.com/en_GB/aftermarket/perkins-platinum-protection.html

Local support, global coverage

- Perkins recognise that the customer relationship is important to machine manufacturers and we can offer a range of flexible solutions to help provide appropriate support, either to the OEM's network or directly to the machine customer
- Perkins information systems enable our distributors to quickly diagnose engine faults and identify the right parts. The Perkins logistics operation is able to dispatch more than 45,000 different parts from stock, reaching the customer within 24 hours
- To find your local distributor: www.perkins.com/distributor

www.perkins.com

Photographs are for illustrative purposes only and may not reflect final specification.
All information in this document is substantially correct at time of printing and may be altered subsequently.
Final weight and dimensions will depend on completed specification.

Publication No. PN3184/06/18 Produced in England ©2018 Perkins Engines Company Limited

 **Perkins**[®]

THE HEART OF EVERY GREAT MACHINE

1200 Series 1206A-E70TTAG3 Diesel Engine – ElectropaK

248.6 kWm (Gross) @ 1500 rpm

240 kWm (Gross) @ 1800 rpm

Technical information

Air inlet

- Standard air cleaners

Control system

- Full electronic control system
- All connectors and wiring looms waterproof and designed to withstand harsh environments
- Flexible and configurable software features and well supported SAE J1939 CAN bus enables highly integrated machines

Cooling system

- Tropical radiator as standard ensures optimal cooling performances all year round in any state
- 50:50 water glycol mix

Flywheels and flywheel housing

- SAE2 flywheel housing

Fuel and fuel system

- Electronic high pressure common rail
- Innovative filter design – ensures maximum protection of the engine
- Flat bottomed, isolated, aluminium sump

Dimensions

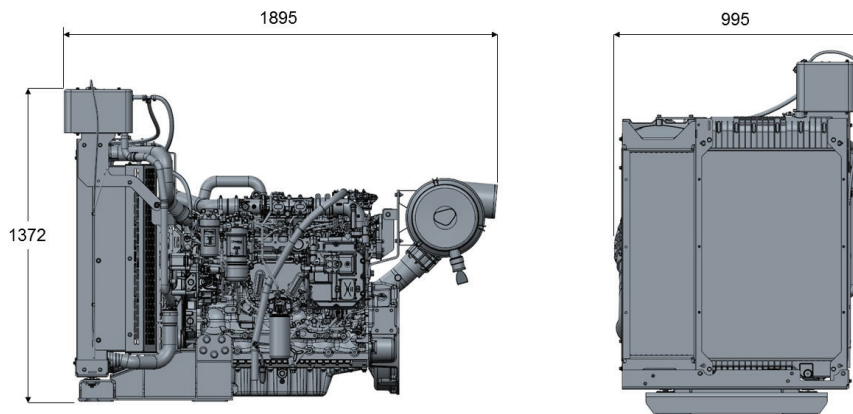

Engine package weights and dimensions		
Length (including air filter)	1895 mm	74.6 in
Width	995 mm	39.2 in
Height	1372 mm	54.0 in
Weight (dry)	807.7 kg	1780.7 lb

www.perkins.com

Photographs are for illustrative purposes only and may not reflect final specification. All information in this document is substantially correct at time of printing and may be altered subsequently. Final weight and dimensions will depend on completed specification.

Publication No. PN3184/06/18 Produced in England ©2018 Perkins Engines Company Limited

 **Perkins**[®]

THE HEART OF EVERY GREAT MACHINE

1200 Series 1206A-E70TTAG3 Diesel Engine – Electropak

248.6 kWm (Gross) @ 1500 rpm

240 kWm (Gross) @ 1800 rpm

Speed rpm	Type of operation	Generator output		Engine power			
				Gross		Net	
		kVA	kWe	kWm	hp	kWm	hp
1500	Prime power	250	200	226.2	303.2	217.2	291.2
	Standby power	275	220	248.6	333.2	238.2	391.4
1800	Prime power	225	180	216.6	290.5	201.6	270.4
	Standby power	250	200	238.6	319.9	223.6	299.8

Power rating %	226.2 kW/1500 rpm Prime		216.6 kW/1800 rpm Prime	
	g/kWh	litres/hr	g/kWh	litres/hr
25	228.8	15.4	257	16.5
50	209.6	28.1	216.4	27.8
75	206.1	41.5	209.3	40.4
100	212.3	56.9	211.7	54.5
110	219.6	64.5	215.2	61.1

www.perkins.com

Photographs are for illustrative purposes only and may not reflect final specification.
All information in this document is substantially correct at time of printing and may be altered subsequently.
Final weight and dimensions will depend on completed specification.

Publication No. PN3184/06/18 Produced in England ©2018 Perkins Engines Company Limited

 **Perkins**[®]

THE HEART OF EVERY GREAT MACHINE

DSE6110/20 MKII

AUTO START & AUTO MAINS FAILURE CONTROL MODULES

DSE6110 MKII

DSE6120 MKII

KEY FEATURES

- Large back-lit text display
- Multiple display languages
- Heated display option available
- DSENet® expansion compatible
- Data logging facility
- Fully configurable via PC using USB communication
- Front panel configuration
- Efficient power save mode
- 3 phase generator sensing
- 3 phase mains (utility) sensing (DSE6120 MKII only)
- Generator/load power monitoring (kW, kV A, kV Ar, pf)
- Accumulated power monitoring (kW h, kVA h, kVAR h)
- Generator/load current monitoring and protection
- Generator overload protection (kW)
- Breaker control via fascia buttons
- Fuel and start outputs, configurable when using CAN
- 4 configurable DC outputs
- 4 configurable analogue/digital inputs
- Support for 0 to 10 V &

- 4 to 20 mA oil pressure sensors
- 6 configurable digital inputs
- Configurable staged loading outputs
- CAN, MPU and alternator speed sensing in one variant
- 3 engine maintenance alarms
- Engine speed protection
- Engine hours counter
- Engine pre-heat
- Engine run-time scheduler
- Engine idle control for starting & stopping
- Fuel pump control
- Real time clock
- Battery voltage monitoring
- Start on low battery voltage
- Configurable remote start input
- 1 alternative configuration
- Comprehensive warning, electrical trip or shutdown protection upon fault condition
- LCD and LED alarm indication
- Customisable information screens
- Configurable event log (100)
- Tier 4 ECO engine support including exhaust fluids & filters

- J1939-75 instrumentation output, configurable CAN instrumentation and alarms
- Start on low battery
- Enhanced alarm functionality
- Low load alarm

KEY BENEFITS

- Automatically transfers between mains (utility) and generator (DSE6120 MKII only)
- Increased input and output expansion capability via DSENet®
- User-friendly set-up and button layout for ease of use
- Multiple parameters are monitored simultaneously which are clearly displayed on a large back-lit text display via multiple languages
- The module can be configured to suit a wide range of applications
- Uses DSE Configuration Suite PC Software for simplified configuration
- Licence-free PC software
- IP65 rating (with optional gasket) offers increased resistance to water ingress

SPECIFICATIONS
DC SUPPLY

CONTINUOUS VOLTAGE RATING
8 V to 35 V Continuous

CRANKING DROPOUTS

Able to survive 0 V for 50 mS, providing supply was at least 10 V before dropout and supply recovers to 5 V. This is achieved without the need for internal batteries. LEDs and backlight will not be maintained during cranking.

MAXIMUM OPERATING CURRENT
100 mA at 12 V, 105 mA at 24 V

MAXIMUM STANDBY CURRENT
60 mA at 12 V, 55 mA at 24 V

MAXIMUM SLEEP CURRENT
40 mA at 12 V, 35 mA at 24 V

GENERATOR & MAINS (UTILITY) VOLTAGE RANGE

15 V to 415 V AC (Ph to N)
26 V to 719 V AC (Ph to Ph)

FREQUENCY RANGE
3.5 Hz to 75 Hz

INPUTS

DIGITAL INPUTS A to F
Negative switching

ANALOGUE INPUT A

Configurable as:
Negative switching digital input
0 V to 10 V
4 mA to 20 mA
0 Ω to 240 Ω

ANALOGUE INPUTS B TO D

Configurable as:
Negative switching digital input
0 Ω to 480 Ω

OUTPUTS
OUTPUT A (FUEL)

10 A short term, 5 A continuous, at supply voltage

OUTPUT B (START)

10 A short term, 5 A continuous, at supply voltage

AUXILIARY OUTPUTS C, D, E & F

2 A DC at supply voltage

DIMENSIONS

OVERALL
216 mm x 158 mm x 43 mm
8.5" x 6.2" x 1.5"

PANEL CUT-OUT

184 mm x 137 mm
7.2" x 5.3"

MAXIMUM PANEL THICKNESS

8 mm
0.3"

STORAGE TEMPERATURE RANGE

-40 °C to +85 °C
-40 °F to +185 °F

OPERATING TEMPERATURE RANGE NON HEATED DISPLAY VARIANT

-30°C to +70°C
-22 °F to +158 °F

HEATED DISPLAY VARIANT

-40 °C to +70 °C
-40 °F to +158 °F

OPTIONAL PARTS

PART	PART NUMBER
IP65 Gasket	020-521

RELATED MATERIALS
TITLE

DSE6110/20 MKII Installation Instructions
DSE6110/20 MKII Operator Manual
DSE6110/20 MKII Configuration Suite PC Manual

PART NO.

053-173
057-226
057-224

DEEP SEA ELECTRONICS PLC UK

Highfield House, Hunmanby Industrial Estate, Hunmanby YO14 0PH
TELEPHONE +44 (0) 1723 890099 **FACSIMILE** +44 (0) 1723 893303
EMAIL sales@deepseapl.com **WEBSITE** www.deepseapl.com

DEEP SEA ELECTRONICS INC USA

3230 Williams Avenue, Rockford, IL 61101-2668 USA
TELEPHONE +1 (815) 316 8706 **FACSIMILE** +1 (815) 316 8708
EMAIL sales@deepseausa.com **WEBSITE** www.deepseausa.com

DSE6110/20 MKII

AUTO START & AUTO MAINS FAILURE CONTROL MODULES

The DSE6110 MKII Auto Start Control Module and the DSE6120 MKII Auto Mains (Utility) Failure Control Module are suitable for a wide variety of single gen-set applications.

Monitoring engine speed, oil pressure, coolant temperature, frequency, voltage, current, power and fuel level, the modules give comprehensive engine and alternator protection. This is indicated on a large back-lit LCD text display via an array of warning, electrical trip and shutdown alarms in multiple languages.

Electronic J1939 (CAN) and non-electronic MPU and alternator sensing engine support for diesel, gas and petrol engines all in one variant. With a number of flexible inputs, outputs and protections, the modules can be easily adapted to suit a wide range of applications.

Through USB Communication both modules can be configured using the DSE Configuration Suite PC Software or through the module's front panel editor.

Using the DSE Configuration Suite PC Software the controller is easy to use and configure which allows alteration of operating parameters, sequences, timers and alarms.

AVAILABLE VARIANTS

- 6110-03 Auto Start with real time clock
- 6120-03 Auto Mains Failure with real time clock

ENVIRONMENTAL TESTING STANDARDS

ELECTRO-MAGNETIC COMPATIBILITY

BS EN 61000-6-2
EMC Generic Immunity Standard for the Industrial Environment
BS EN 61000-6-4
EMC Generic Emission Standard for the Industrial Environment

ELECTRICAL SAFETY

BS EN 60950
Safety of Information Technology Equipment, including Electrical Business Equipment

TEMPERATURE

BS EN 60068-2-1
Ab/Ae Cold Test -30 °C
BS EN 60068-2-2
Bb/Be Dry Heat +70 °C

VIBRATION

BS EN 60068-2-6
Ten sweeps in each of three major axes
5 Hz to 8 Hz at +/-7.5 mm,
8 Hz to 500 Hz at 2 GN

HUMIDITY

BS EN 60068-2-30
Db Damp Heat Cyclic 20/55 °C at 95% RH 48 Hours
BS EN 60068-2-78
Cab Damp Heat Static 40 °C at 93% RH 48 Hours

SHOCK

BS EN 60068-2-27
Three shocks in each of three major axes
15 GN in 11 mS

DEGREES OF PROTECTION PROVIDED BY ENCLOSURES

BS EN 60529
IP65 - Front of module when installed into the control panel with the optional sealing gasket.

COMPREHENSIVE FEATURE LIST TO SUIT A WIDE VARIETY OF GEN-SET APPLICATIONS

