

180 KVA DIESEL GENERATOR

FEATURES & BENEFITS

- Maximum 200 kVA, 380V, 1500 RPM
- Constant voltage AVR (Automatic Voltage Regulator)
- 24V Electric Starter
- 320 Litre Fuel Tank, 10 Hours @ 75% load
- Silent Version (± 72 dBa)
- 6 Cylinder, in-line, Water cooled, Turbocharged & Aftercooled
- Three Phase Output
- DeepSea DSE6120 Digital Control Panel
- Low oil pressure system
- Low water cut out engine protection



 Perkins

 DEEP SEA
DSE ELECTRONICS

 LEROY-SOMER

| GENERAL DATA | |
|--------------------------------|-------------|
| Model: | BPD180S3-P |
| Prime Power (P.R.P): | 180 kVA |
| Stand-by Power (L.T.P): | 200 kVA |
| Amps: | 303 A |
| Power Factor / COS: | 0.8 |
| Frequency: | 50 Hz |
| Voltage: | 380 V |
| Phases: | Three Phase |
| Engine Speed: | 1500 RPM |
| Length: | 3150 mm |
| Width: | 1100 mm |
| Height: | 1680 mm |
| Weight: | 2320 kg's |
| Tank Capacity: | 320 l |

| ADDITIONAL | |
|--------------------------------|----------------------|
| Running Time: | 10 Hours @ 75% load |
| Structure Type: | Silent |
| Noise Level (7m): | 72 dBA |
| Auto Voltage Regulator: | Constant voltage AVR |
| ISO9001 Certified: | Yes |
| CE Certified: | Yes |
| Fuel Cons. @ 100% Load: | 41.4 |
| Fuel Cons. @ 75% Load: | 31.0 |
| Fuel Cons. @ 50% Load: | 20.7 |

| ENGINE DATA | |
|------------------------------|---------------------------------------------------------------|
| Brand: | Perkins |
| Model: | 1106A-70TAG3 |
| Type: | 6 Cylinder, in-line, Water cooled, Turbocharged & Aftercooled |
| Starting System: | 24V Electric Starter |
| Auto-Decompression: | Yes |
| Cubic Capacity (l): | 7.01 |
| Compression Ratio: | 18.2:1 |
| Rated Power (kW/RPM): | 180 / 1500 |
| Fuel Type: | Diesel |
| Lube Oil: | 15W40 |
| Low Pressure Alert: | Yes |
| Low Fuel Cut Out: | Yes |

| CONTROL PANEL | |
|-----------------------------|-----------------------|
| Model: | DeepSea DSE6120 |
| Type: | Digital Control Panel |
| Analogue Inputs: | 6 |
| Mains Phase Voltage: | Yes |
| Mains Line Voltage: | Yes |

| ALTERNATOR | |
|-------------------------|-------------------------|
| Model: | Leroy Somer - TAL-A46-C |
| Pole Number: | 4 |
| Excitation Mode: | Self Excitation |

Johannesburg
011 397 7373

Pietermaritzburg
033 007 0812

Nelspruit
013 007 1753

Bloemfontein
051 001 1429

1106A-70TAG3

1100

180.2 kWm (Gross) @ 1500 rpm
197.7 kWm (Gross) @ 1800 rpm

Series

Electropak

Basic technical data

| | |
|------------------------------|-----------------------------------------|
| Number of cylinders | 6 |
| Cylinder arrangement | Inline |
| Cycle | 4 stroke |
| Induction system | Turbocharged and air charge cooled |
| Combustion system | Direct injection diesel |
| Compression ratio | 16.5:1 |
| Bore | 105 mm |
| Stroke | 135 mm |
| Cubic capacity | 7.01 litres |
| Direction of rotation | Anticlockwise when viewed from flywheel |
| Firing order | 1, 5, 3, 6, 2, 4 |
| Estimated total weight (dry) | 743 kg |
| Estimated total weight (wet) | 777 kg |

Overall dimensions, Electropak

| | |
|-----------------------------|---------|
| Height | 1092 mm |
| Length (air cleaner fitted) | 1706 mm |
| Width | 756 mm |

Moments of inertia

| | |
|------------------------------|------------------------------|
| Engine rotational components | 0.27 kgm ² |
| Flywheel | 1.26 kgm ² (SAE2) |

Centre of gravity, Electropak

| | |
|-----------------------------------------------|--------|
| Forward from rear of block (wet) | 476 mm |
| Above crankshaft centre line (wet) | 176 mm |
| Offset to RHS of crankshaft centre line (wet) | -16 mm |

Performance

| | |
|--------------------------------------|---------|
| Speed variation at constant load | ± 0.75% |
| Cyclic irregularity at standby power | 0.028 |
| All ratings within | ± 5% |

Note: All data based on operation to ISO 3046-1:2002 standard reference conditions.

Sound level

Average sound pressure level for prime power @ 1 m TBA dB(A)

Test conditions

| | |
|----------------------------------------|-----------------|
| Air temperature | 25°C |
| Barometric pressure | 100 kPa |
| Relative humidity | 31.5% |
| Air inlet restriction at maximum power | 3 kPa (nominal) |
| Exhaust back pressure at maximum power | 6 kPa (nominal) |
| Fuel temperature | 40°C |

Note: If the engine is to operate in ambient conditions other than those of the test conditions, suitable adjustments must be made for these changes. For full details, contact Perkins Technical Service Department.

General installation

| General Installation | Units | Prime | Standby | Prime | Standby |
|--------------------------------------------------------------------|---------------------|--------|---------|--------|---------|
| | | 50 Hz | | 60 Hz | |
| | | | | | |
| Gross engine power | kW | 162.7 | 180.2 | 179.7 | 197.7 |
| Gross BMEP | kPa | 1856.0 | 2056.5 | 1709.0 | 1880.2 |
| Mean piston speed | metres/s | 6.8 | | 8.1 | |
| ElectropaK nett engine power | kW | 157.7 | 175.2 | 171.7 | 189.7 |
| Engine coolant flow (against 35 kPa restriction) | litres/min | 142 | | 170 | |
| Combustion air flow (at STP) | m ³ /min | 12.74 | 13.45 | 16.55 | 17.37 |
| Exhaust gas flow (maximum) | m ³ /min | 30.37 | 32.28 | 37.45 | 40.66 |
| Exhaust gas temperature (maximum) in manifold (after turbocharger) | °C | 487 | | 486 | |
| Nett engine thermal efficiency | % | 40.0 | 40.4 | 37.3 | 36.8 |
| Typical genset electrical output (0.8pf 25°C) | kWe | 144 | 160 | 156.8 | 173.0 |
| | kVA | 180 | 200 | 196.9 | 216.5 |
| Regenerative power (estimated) | kW | 8.1 | | 9 | |
| Assumed alternator efficiency | % | 91.3 | | 91.3 | |

Rating definitions

Prime power

Unlimited hours usage, with an average load factor of 80% over each 24 hour period. A 10% overload is available for 1 hour in every 12 hours operation.

Standby power

Limited to 500 hours annual usage, with an average load factor of 80% of the published standby power rating over each 24 hour period. Up to 300 hours of annual usage may be run continuously. No overload is permitted on standby power.

Energy balance

| Designation | Units | Prime | Standby | Prime | Standby |
|--------------------------------------|-------|-------|---------|-------|---------|
| | | 50 Hz | | 60 Hz | |
| | | | | | |
| Heat in fuel | kW | 394.2 | 433.6 | 460.9 | 514.8 |
| Power to cooling fan | kW | 5.0 | | 8.0 | |
| Power to coolant and lubricating oil | kW | 71.9 | 77.9 | 80.8 | 92.5 |
| Power to exhaust | kW | 119.1 | 129.6 | 144.7 | 162.4 |
| Energy to charge coolers | kW | 28.7 | 32.9 | 41.9 | 46.8 |
| Power to radiation | kW | 11.8 | 13.0 | 13.8 | 15.4 |

Cooling system

Cooling pack

| | |
|----------------------------|-------------------------|
| Overall weight (wet) | 45 kg |
| Overall face area | 469,200 mm ² |
| Width | 684 mm |
| Height | 690 mm |

Radiator

| | |
|--------------------------------------|-------------------------------|
| Face area | 303,600 mm ² |
| Number of rows and materials | 4 rows, Aluminium |
| Matrix density and material | 11.3 fins per inch, Aluminium |
| Width of matrix | 440 mm |
| Height of matrix | 690 mm |
| Pressure cap setting (minimum) | 110 kPa |

Charge cooler

| | |
|------------------------------------|-----------------------------|
| Face area | 151,800 mm ² |
| Number of rows and materials | 2 rows, Aluminium |
| Matrix density and material | 10 fins per inch, Aluminium |
| Width of matrix | 220 mm |
| Height of matrix | 690 mm |

Fan

| | |
|---------------------------|-------------------------|
| Diameter | 635 mm |
| Drive ratio | 1.25:1 |
| Number of blades | 7 |
| Material | Nylon |
| Type | Pusher |
| Air flow @ 1500 rpm | 222 m ³ /min |
| Power @ 1500 rpm | 4.5 kW |
| Air flow @ 1800 rpm | 282 m ³ /min |
| Power @ 1800 rpm | 8 kW |

Coolant

| | |
|--------------------------------------------------------------------|------------------------------------------------------|
| Total system capacity | 20.5 litres |
| System drawdown capacity | 10% |
| Engine capacity | 9.5 litres |
| Maximum top tank temperature | 110°C |
| Temperature rise across engine (maximum rating dependent) | 6°C - 12°C |
| Maximum permissible external system resistance | 35 kPa |
| Thermostat operation range | 82°C to 93°C |
| Shutdown switch setting | 118°C |
| Coolant pump method of drive | Gear |
| Recommended coolant immersion heater rating (minimum) | 0.75 kW |
| Recommended coolant | BS6580 - 1992, ASTM D3306 and ELC coolants to 1E1966 |

Duct allowance

Maximum additional restriction (duct allowance to cooling airflow and resultant minimum air flow) - Standby power

| Description | rpm | kPa | m ³ /min |
|-----------------------------------------------|------|-------|---------------------|
| Duct allowance with inhibited coolant at 53°C | | | |
| Minimum air flow | 1500 | 0.125 | 204 |
| | 1800 | 0.12 | 258 |
| Duct allowance with inhibited coolant at 46°C | | | |
| Minimum air flow | 1500 | 0.2 | 184 |
| | 1800 | 0.2 | 228 |

Electrical system

| | |
|----------------------------------------------------------------------------------------------|-------------------|
| Alternator | 8SI |
| Alternator voltage | 12 volts |
| Alternator output | 65 amps |
| Starter | 38 MT |
| Starter motor voltage | 12 volts |
| Starter motor power | 5.0 kW |
| Number of teeth on the flywheel | 134 |
| Pull-in and hold-in current of starter motor solenoid @ 25°C maximum ⁽¹⁾ | 12 volts 320 amps |
| Hold-in current of starter motor solenoid @ 25°C maximum ⁽¹⁾ | 12 volts 25 amps |
| Engine stop method | Solenoid |

¹ All leads to rated at 10 amps minimum

Cold start recommendations

Minimum required cranking speed over TDC

| | 5 to -10°C | -10 to -20°C | -20 to -25°C |
|-----------------------------|-------------|--------------|--------------|
| Oil | 15W40 | 10W40 | 5W40 |
| Starter | 38 MT | | |
| Battery | 2 x 950 CCA | | |
| Cranking current | 850 A | | |
| Aids | None | Glowplugs | |
| Minimum mean cranking speed | 130 rpm | 100 rpm | 100 rpm |

Note: Battery capacity is defined by the 20 hour rate.

Note: If a change to a low viscosity oil is made, the cranking torque necessary at low ambient temperatures is much reduced. The starting equipment has been selected to take advantage of this. It is important to change to the appropriate multigrade oil in anticipation of operating in low ambient temperatures.

Exhaust system

| | |
|-----------------------------------------|---------|
| Maximum back pressure - 1500 rpm | 6.0 kPa |
| Exhaust outlet, internal diameter | 72 mm |

Fuel system

Injection components

Injector Mechanical
 Fuel pump..... DP210G

Fuel priming

Priming pump type Manual
 Maximum priming time..... 90 seconds

Fuel feed

Maximum fuel flow 3 litres/minute
 Maximum suction head at engine fuel pump inlet..... 50 kPa
 Maximum static pressure head 50 kPa
 Fuel temperature at engine fuel pump inlet..... 85°C
 Tolerance on fuel consumption..... ± 5%

Fuel specification

Fuel standard..... Various (contact Perkins Technical Department)

Fuel consumption

| Load | Type of operation and application | | | |
|------------------|-----------------------------------|-------|-------------|-------|
| | g/kWh | | litres/hour | |
| | 50 Hz | 60 Hz | 50 Hz | 60 Hz |
| 110% Prime power | 203.1 | 216.7 | 43.7 | 51.7 |
| Prime power | 203.5 | 214.7 | 39.6 | 46.4 |
| 75% Prime power | 209.3 | 221.5 | 30.7 | 35.7 |
| 50% Prime power | 193.9 | 206.2 | 18.8 | 22.2 |
| 25% Prime power | 217.5 | 224.7 | 10.5 | 12.1 |

Induction system

Maximum air intake restriction

Clean filter 3 kPa
 Dirty filter..... 5 kPa
 Air filter type..... Paper element

Lubrication system

Maximum total system oil capacity 18.0 litres
 Minimum oil capacity in sump 12.5 litres
 Maximum oil capacity in sump 16.1 litres
 Maximum engine operating angles -
 Front up, front down, right side, left side..... 25°
 Sump drain plug tapping size 3/4 - 16 UNF
 Shutdown switch setting (where fitted)

Lubricating oil

Relief valve opening pressure 460 kPa
 Pressure at maximum speed 520 kPa
 Maximum continuous oil temperature (in rail)..... 125°C
 Oil consumption at full load (% of fuel) < 0.1

Recommended SAE viscosity

A multigrade oil must be used which conforms to API CH4 or C14
 ACEA E5 must be used, see illustration below:

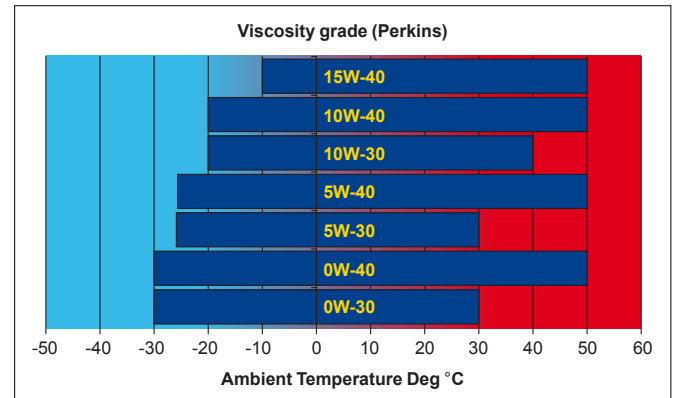

Mountings

Maximum static bending moment at rear face of block..... 1130 Nm
 Maximum permissible overhung load
 on the flywheel..... Calculated on request
 Maximum bending moment at rear of flywheel housing..... ± 3000 in Shock Nm

Load acceptance

The data below complies with the requirements of classification 3 and 4
 of ISO 8528-12 and G2 operating limits stated in ISO 8528-5.

Initial load application: When engine reaches rated speed
 (15 seconds maximum after engine starts to crank).

| Description | Units | 50 Hz | 60 Hz |
|-------------------------------|---------|-------|-------|
| % of prime power | % | 75 | 85 |
| Load | kWe | 109 | 150 |
| Transient frequency deviation | % | <10 | <10 |
| Frequency recovery time | Seconds | 1.6 | 2.3 |

Noise data

Noise levels

| Position | Noise level [dB(A)] | | | |
|----------|---------------------|-------|---------|-------|
| | Prime power | | Standby | |
| | 50 Hz | 60 Hz | 50 Hz | 60 Hz |
| 1 | 97.49 | 100.2 | 96.67 | 99.7 |
| 2 | 95.15 | 97.3 | 93.77 | 97.1 |
| 3 | 94.68 | 97.4 | 94.21 | 97 |
| 4 | 93.6 | 97.2 | 93.42 | 96.8 |
| 5 | 98.57 | 102.5 | 98.68 | 101.9 |
| 6 | 95.15 | 99.1 | 95.14 | 98.8 |

Noise reference level 65 dB(A)

1/3 octave analysis: TBC

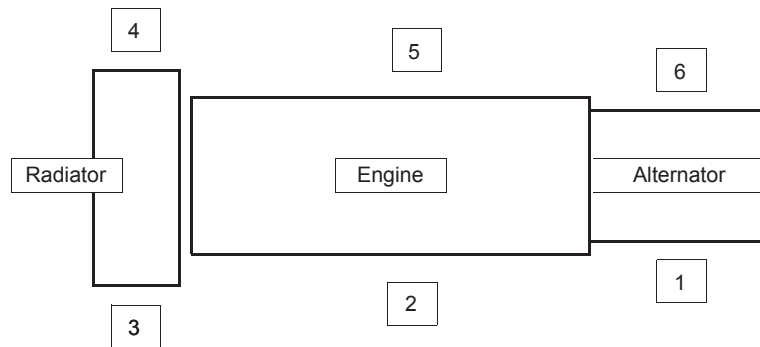

1106A-70TAG3 - Left side view

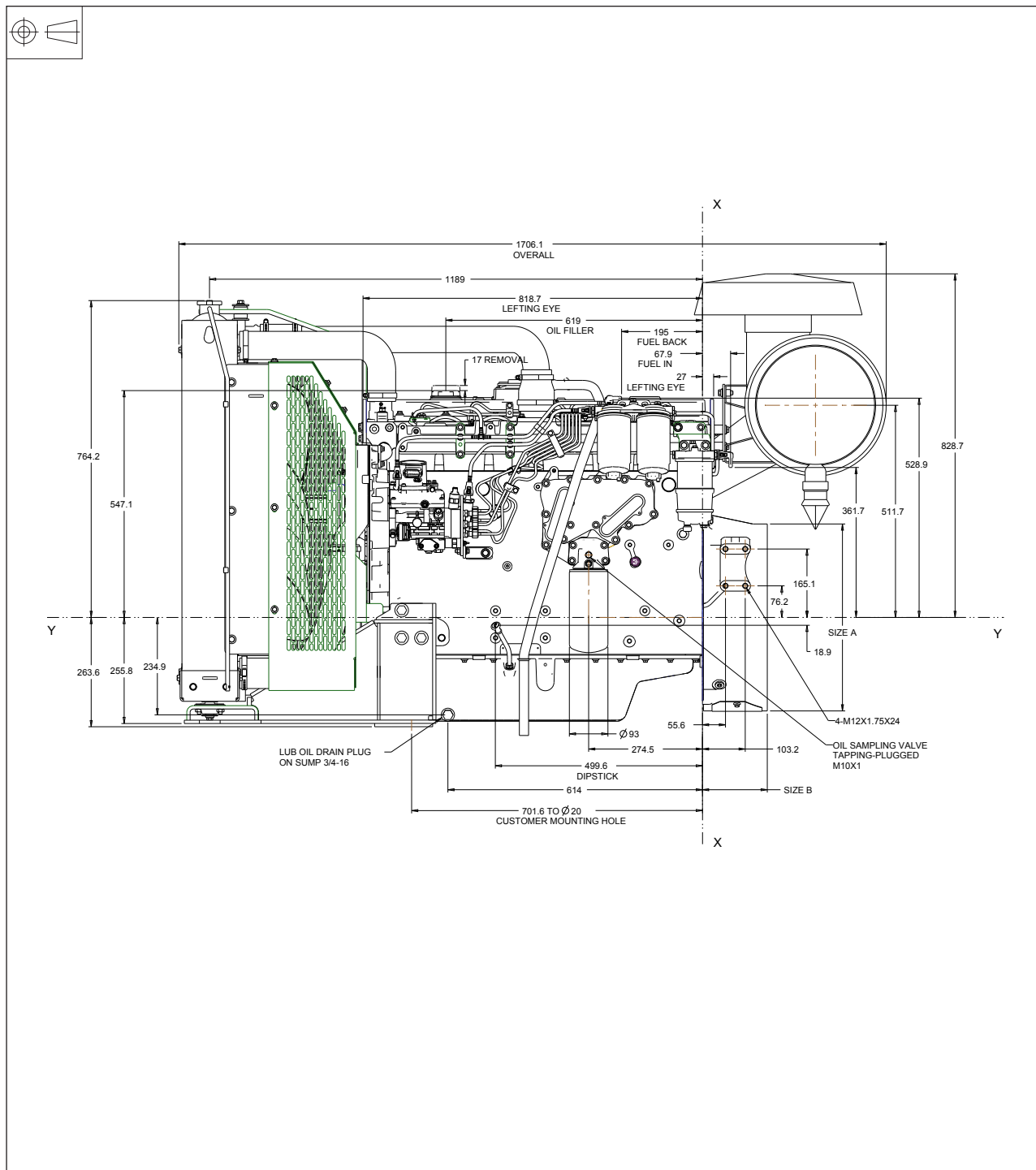

Flywheel and housing options

| Option | Part | Size A | Size B | Description |
|--------|---------------|---------|--------|---------------------------------------|
| 1 | C0001 & D0004 | ø 450.9 | 153.37 | The type is SAE 3 Use on TAG 2 & 4 |
| 2 | C0074 & D0090 | ø 489 | 134.6 | The type is SAE 2 Use on TAG 3 & 4 |

1106A-70TAG3 - Front view

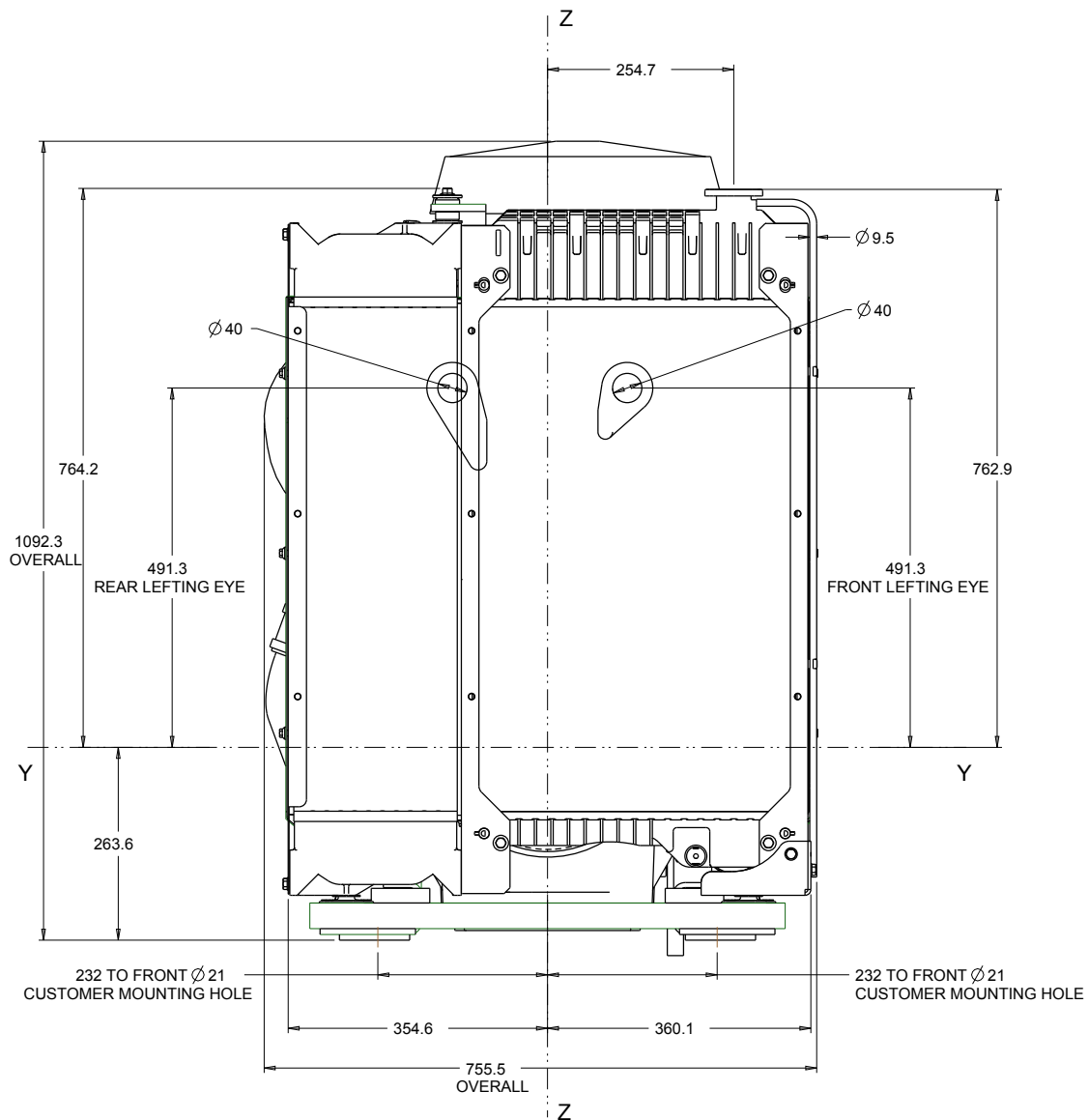

1106A-70TAG3 - Right side view

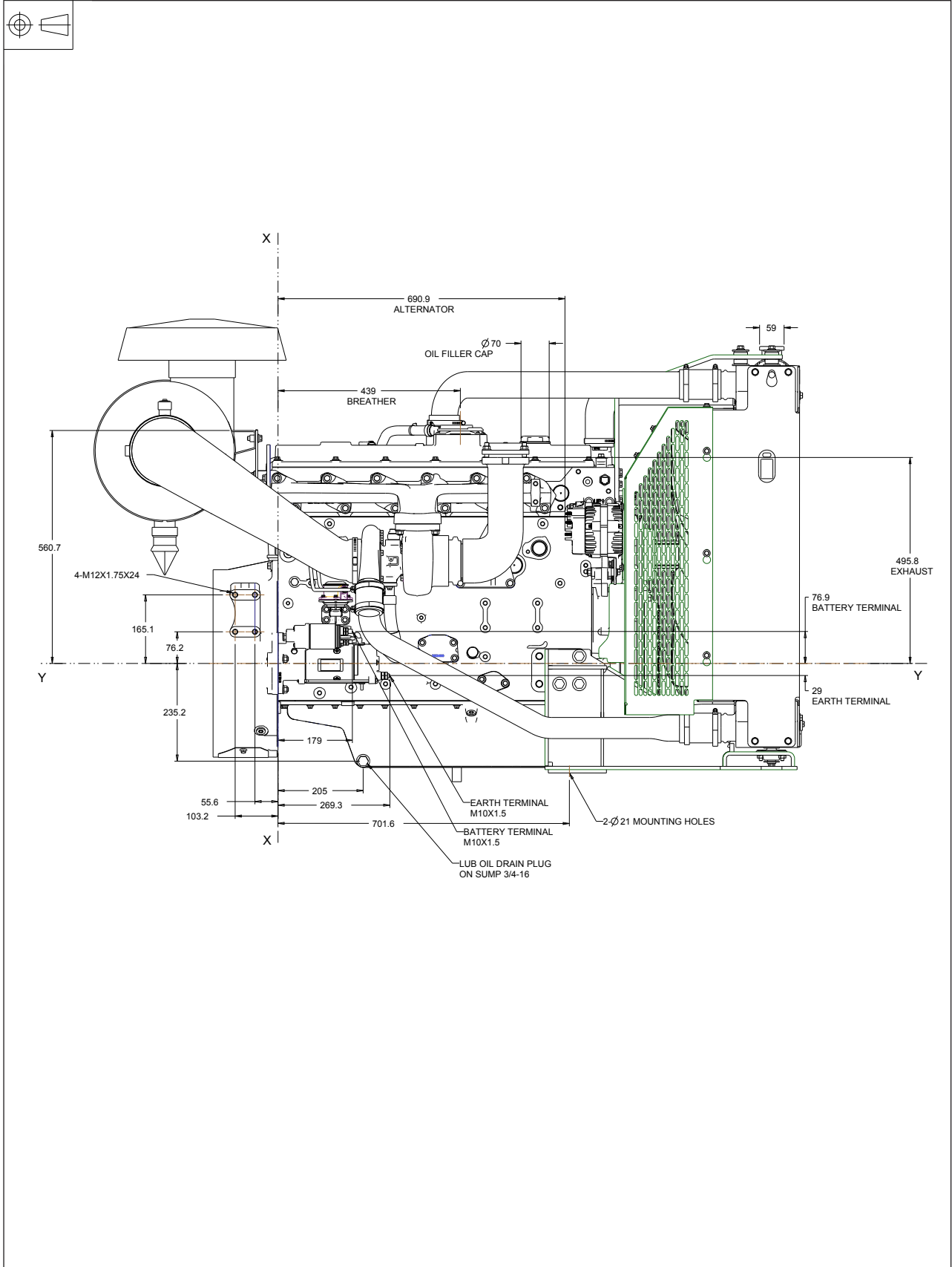

1106A-70TAG3 - Rear view

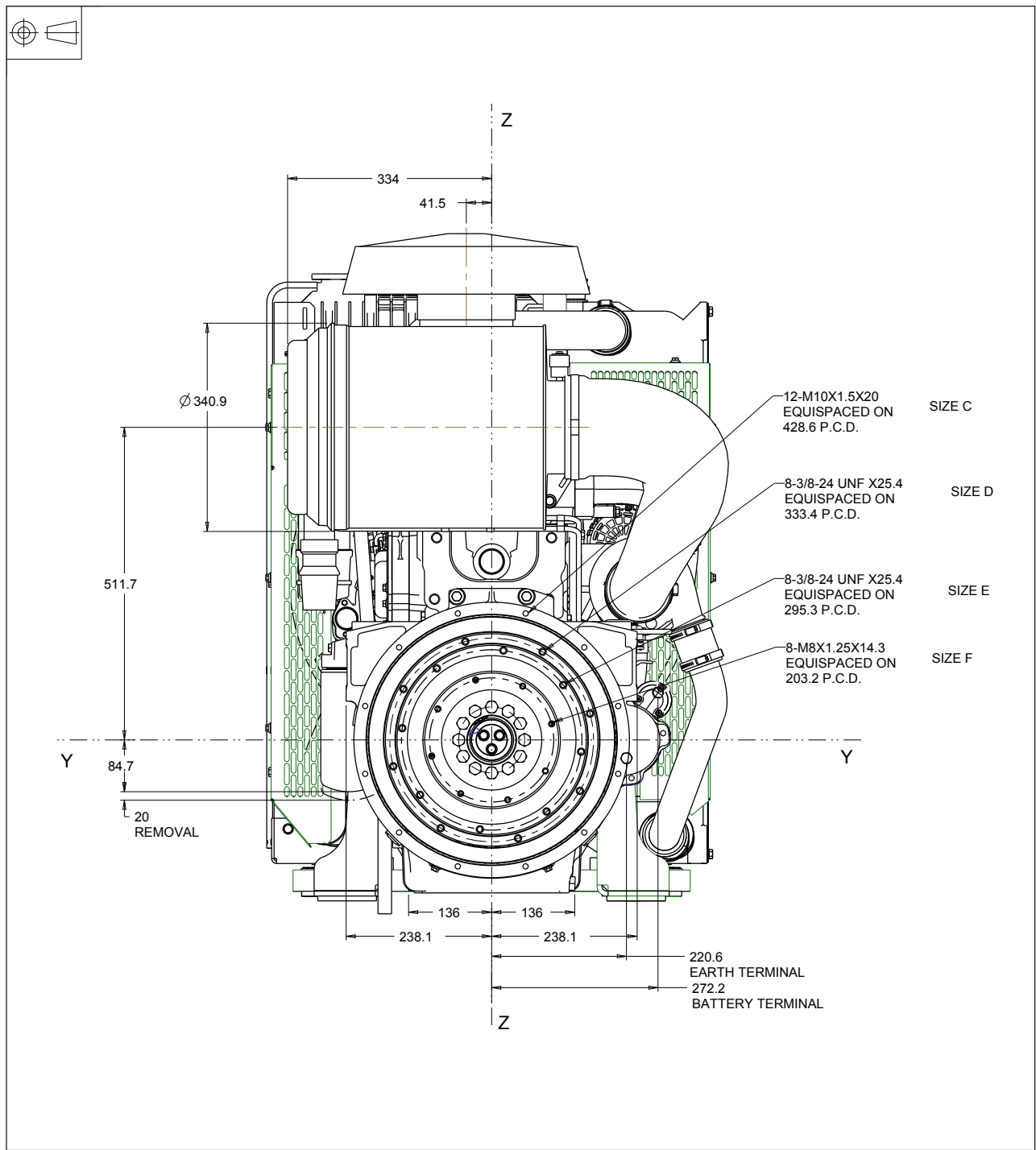

| Option | Part | Size C | Size D | Size E | Size F |
|--------|---------------|--------------------------------------------------------|-----------------------------------------------------------|-----------------------------------------------------------|-------------------------------------------------------|
| 1 | C0001 & D0004 | 12- M10 x 1.5 x 20 EQUISPACED ON 428.63 P.C.DIA | 8- 3/8 - 24 UNF x 25.4 EQUISPACED ON 333.38 P.C.DIA | 8- 3/8 - 24 UNF x 25.4 EQUISPACED ON 295.28 P.C.DIA | 8- M8 x 1.25 x 14.3 EQUISPACED ON 203.2 P.C.DIA |
| 2 | C0074 & D0090 | 12- M10 x 1.5 x 20 EQUISPACED ON 466.725 P.C.DIA | 8- M10 x 1.5 x 25.4 EQUISPACED ON 333.38 P.C.DIA | | |

1106A-70TAG3 - Plan view

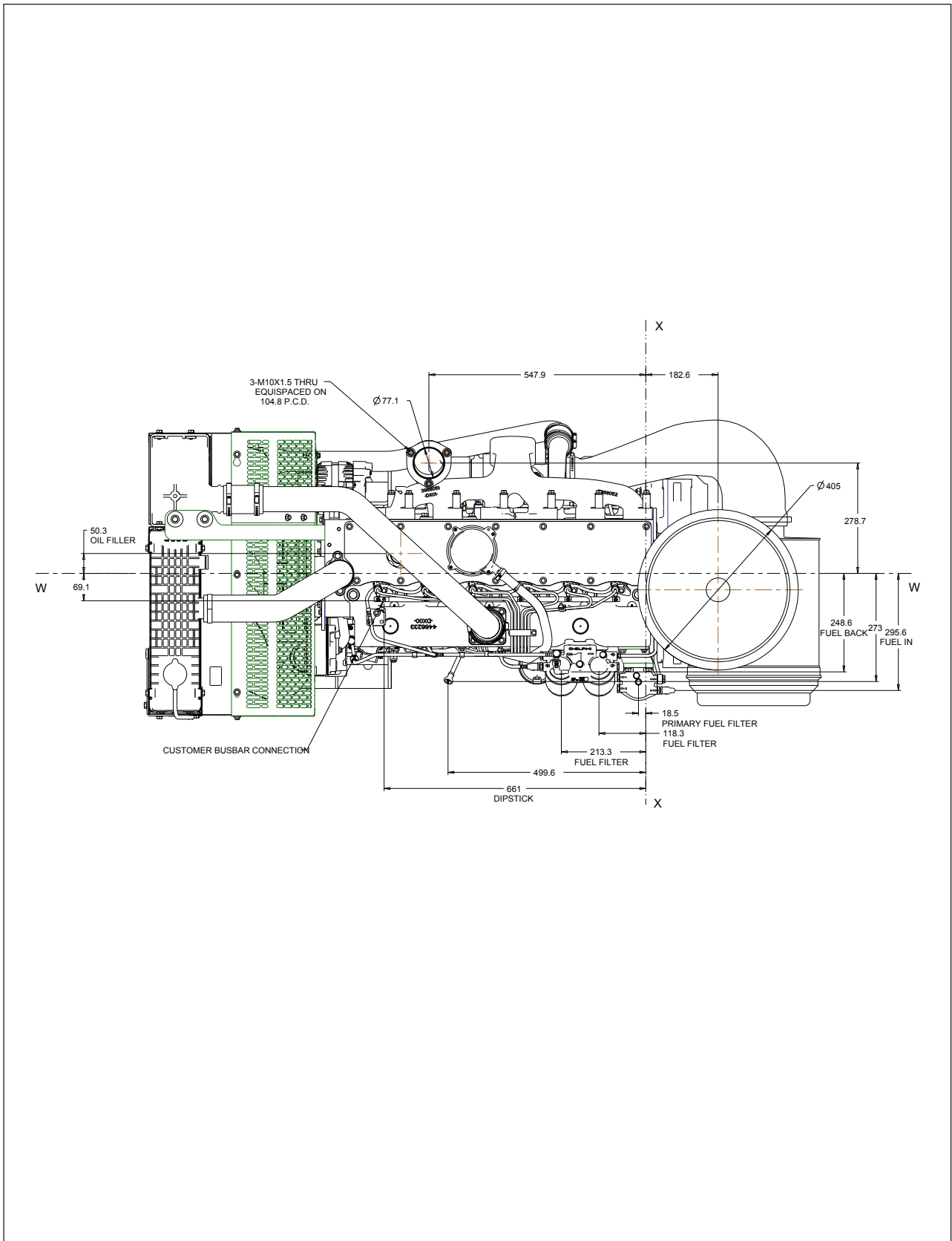

DSE6110/20 MKII

AUTO START & AUTO MAINS FAILURE CONTROL MODULES

DSE6110 MKII

DSE6120 MKII

KEY FEATURES

- Large back-lit text display
- Multiple display languages
- Heated display option available
- DSENet® expansion compatible
- Data logging facility
- Fully configurable via PC using USB communication
- Front panel configuration
- Efficient power save mode
- 3 phase generator sensing
- 3 phase mains (utility) sensing (DSE6120 MKII only)
- Generator/load power monitoring (kW, kV A, kV Ar, pf)
- Accumulated power monitoring (kW h, kVA h, kVAr h)
- Generator/load current monitoring and protection
- Generator overload protection (kW)
- Breaker control via fascia buttons
- Fuel and start outputs, configurable when using CAN
- 4 configurable DC outputs
- 4 configurable analogue/digital inputs
- Support for 0 to 10 V &

- 4 to 20 mA oil pressure sensors
- 6 configurable digital inputs
- Configurable staged loading outputs
- CAN, MPU and alternator speed sensing in one variant
- 3 engine maintenance alarms
- Engine speed protection
- Engine hours counter
- Engine pre-heat
- Engine run-time scheduler
- Engine idle control for starting & stopping
- Fuel pump control
- Real time clock
- Battery voltage monitoring
- Start on low battery voltage
- Configurable remote start input
- 1 alternative configuration
- Comprehensive warning, electrical trip or shutdown protection upon fault condition
- LCD and LED alarm indication
- Customisable information screens
- Configurable event log (100)
- Tier 4 ECO engine support including exhaust fluids & filters

- J1939-75 instrumentation output, configurable CAN instrumentation and alarms
- Start on low battery
- Enhanced alarm functionality
- Low load alarm

KEY BENEFITS

- Automatically transfers between mains (utility) and generator (DSE6120 MKII only)
- Increased input and output expansion capability via DSENet®
- User-friendly set-up and button layout for ease of use
- Multiple parameters are monitored simultaneously which are clearly displayed on a large back-lit text display via multiple languages
- The module can be configured to suit a wide range of applications
- Uses DSE Configuration Suite PC Software for simplified configuration
- Licence-free PC software
- IP65 rating (with optional gasket) offers increased resistance to water ingress

SPECIFICATIONS
DC SUPPLY
CONTINUOUS VOLTAGE RATING
8 V to 35 V Continuous

CRANKING DROPOUTS

Able to survive 0 V for 50 mS, providing supply was at least 10 V before dropout and supply recovers to 5 V. This is achieved without the need for internal batteries. LEDs and backlight will not be maintained during cranking.

MAXIMUM OPERATING CURRENT
100 mA at 12 V, 105 mA at 24 V

MAXIMUM STANDBY CURRENT
60 mA at 12 V, 55 mA at 24 V

MAXIMUM SLEEP CURRENT
40 mA at 12 V, 35 mA at 24 V

GENERATOR & MAINS (UTILITY) VOLTAGE RANGE

15 V to 415 V AC (Ph to N)
26 V to 719 V AC (Ph to Ph)

FREQUENCY RANGE
3.5 Hz to 75 Hz

INPUTS
DIGITAL INPUTS A to F
Negative switching

ANALOGUE INPUT A

Configurable as:
Negative switching digital input
0 V to 10 V
4 mA to 20 mA
0 Ω to 240 Ω

ANALOGUE INPUTS B TO D

Configurable as:
Negative switching digital input
0 Ω to 480 Ω

OUTPUTS
OUTPUT A (FUEL)

10 A short term, 5 A continuous, at supply voltage

OUTPUT B (START)

10 A short term, 5 A continuous, at supply voltage

AUXILIARY OUTPUTS C, D, E & F

2 A DC at supply voltage

DIMENSIONS
OVERALL
216 mm x 158 mm x 43 mm
8.5" x 6.2" x 1.5"

PANEL CUT-OUT

184 mm x 137 mm
7.2" x 5.3"

MAXIMUM PANEL THICKNESS

8 mm
0.3"

STORAGE TEMPERATURE RANGE

-40 °C to +85 °C
-40 °F to +185 °F

OPERATING TEMPERATURE RANGE
NON HEATED DISPLAY VARIANT
-30°C to +70°C
-22 °F to +158 °F

HEATED DISPLAY VARIANT

-40 °C to +70 °C
-40 °F to +158 °F

OPTIONAL PARTS

| PART | PART NUMBER |
|-------------|-------------|
| IP65 Gasket | 020-521 |

RELATED MATERIALS
TITLE

DSE6110/20 MKII Installation Instructions
DSE6110/20 MKII Operator Manual
DSE6110/20 MKII Configuration Suite PC Manual

PART NO.

053-173
057-226
057-224

DEEP SEA ELECTRONICS PLC UK

Highfield House, Hunmanby Industrial Estate, Hunmanby YO14 0PH
TELEPHONE +44 (0) 1723 890099 **FACSIMILE** +44 (0) 1723 893303
EMAIL sales@deepseapl.com **WEBSITE** www.deepseapl.com

DEEP SEA ELECTRONICS INC USA

3230 Williams Avenue, Rockford, IL 61101-2668 USA
TELEPHONE +1 (815) 316 8706 **FACSIMILE** +1 (815) 316 8708
EMAIL sales@deepseausa.com **WEBSITE** www.deepseausa.com

DSE6110/20 MKII

AUTO START & AUTO MAINS FAILURE CONTROL MODULES

The DSE6110 MKII Auto Start Control Module and the DSE6120 MKII Auto Mains (Utility) Failure Control Module are suitable for a wide variety of single gen-set applications.

Monitoring engine speed, oil pressure, coolant temperature, frequency, voltage, current, power and fuel level, the modules give comprehensive engine and alternator protection. This is indicated on a large back-lit LCD text display via an array of warning, electrical trip and shutdown alarms in multiple languages.

Electronic J1939 (CAN) and non-electronic MPU and alternator sensing engine support for diesel, gas and petrol engines all in one variant. With a number of flexible inputs, outputs and protections, the modules can be easily adapted to suit a wide range of applications.

Through USB Communication both modules can be configured using the DSE Configuration Suite PC Software or through the module's front panel editor.

Using the DSE Configuration Suite PC Software the controller is easy to use and configure which allows alteration of operating parameters, sequences, timers and alarms.

AVAILABLE VARIANTS

- 6110-03 Auto Start with real time clock
- 6120-03 Auto Mains Failure with real time clock

ENVIRONMENTAL TESTING STANDARDS

ELECTRO-MAGNETIC COMPATIBILITY

BS EN 61000-6-2
EMC Generic Immunity Standard for the Industrial Environment
BS EN 61000-6-4
EMC Generic Emission Standard for the Industrial Environment

ELECTRICAL SAFETY

BS EN 60950
Safety of Information Technology Equipment, including Electrical Business Equipment

TEMPERATURE

BS EN 60068-2-1
Ab/Ae Cold Test -30 °C
BS EN 60068-2-2
Bb/Be Dry Heat +70 °C

VIBRATION

BS EN 60068-2-6
Ten sweeps in each of three major axes
5 Hz to 8 Hz at +/-7.5 mm,
8 Hz to 500 Hz at 2 GN

HUMIDITY

BS EN 60068-2-30
Db Damp Heat Cyclic 20/55 °C at 95% RH 48 Hours
BS EN 60068-2-78
Cab Damp Heat Static 40 °C at 93% RH 48 Hours

SHOCK

BS EN 60068-2-27
Three shocks in each of three major axes
15 GN in 11 mS

DEGREES OF PROTECTION PROVIDED BY ENCLOSURES

BS EN 60529
IP65 - Front of module when installed into the control panel with the optional sealing gasket.

COMPREHENSIVE FEATURE LIST TO SUIT A WIDE VARIETY OF GEN-SET APPLICATIONS

